



5-year warranty

Type overview

Type	Stroke
BGVL	0.6" [15 mm] LV, 3/4" [20 mm] SV

Technical data

Functional data	Fluid	chilled or hot water and steam
	Fluid Temp Range (water)	Please Refer to Manufacturer's Valve Specifications
	Mounting Position	360°
	Applicable valve size	0.5...2" [15...50]
Materials	Hardware	SS and Nickel plated steel
	Frame, plate, base	aluminum
	Coupling	GF Nylon supplied
Suitable actuators	Non-Spring	LVB(X) SVB(X)
	Electrical fail-safe	LVKB(X) SVKB(X)

For close-off pressure reference Select Pro or retrofit technical documentation.

Product features

Default/Configuration	The default set up for a BGVL linkage will be factory installed along with a LV or SV series actuator. Included in the kit will be all the necessary hardware to facilitate mounting to the Belimo Globe Valve.
Application	The BGVL kit is designed to easily attach LV and SV series actuators to Belimo Globe Valves. The tapered bonnet and notched stem design allow easy installation of the BGVL on 1/2" to 2" two-way or three-way valves in both normally open and normally closed configurations.
Operation	The BGVL linkage with actuator will provide 20 mm of linear travel to accommodate a wide range of valve sizes.

Dimensions

Type	Weight
BGVL	1.1 lb [0.50 kg]

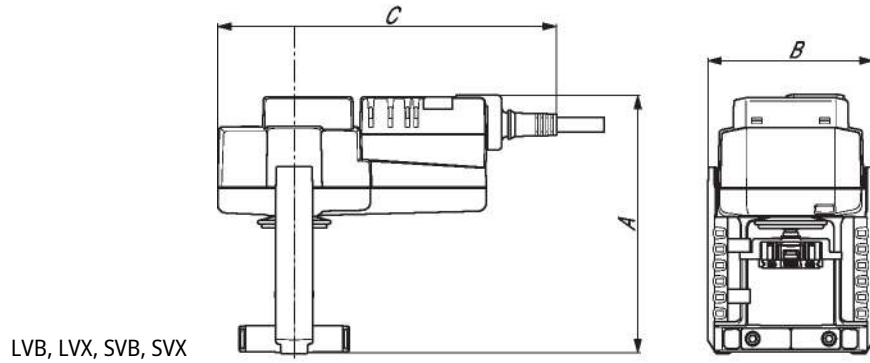

LVB, LVX, SVB, SVX

A	B	C
6.0" [152]	3.8" [97]	7.9" [201]

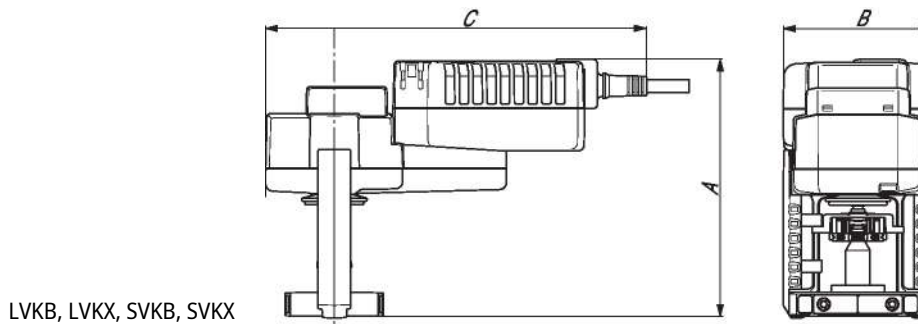

LVKB, LVKX, SVKB, SVKX

A	B	C
6.7" [171]	3.8" [97]	8.1" [206]



5-year warranty



Technical data

Electrical data	Nominal voltage	AC 24 V
	Nominal voltage frequency	50/60 Hz
	Power consumption in operation	2.5 W
	Power consumption in rest position	1.5 W
	Transformer sizing	6 VA (class 2 power source)
	Electrical Connection	18 GA plenum cable, 3 ft [1 m], with 1/2" conduit connector, degree of protection NEMA 2 / IP54
	Overload Protection	electronic throughout full stroke
	Electrical Protection	actuators are double insulated
	Functional data	Actuating force motor
Position feedback U note		No Feedback
Bridging time (PF)		2 s
Pre-charging time		5...20 s
Direction of motion motor		selectable with switch
Direction of motion fail-safe		reversible with switch
Manual override		4 mm hex crank (shipped w/actuator)
Stroke		0.75" [19 mm]
Running Time (Motor)		90 s /
Running time motor variable		90 or 150 s
Running time fail-safe		<35 s
Noise level, motor		55 dB(A)
Noise level, fail-safe		60 dB(A)
Position indication	Mechanically, with pointer	
Safety data	Degree of protection IEC/EN	IP54
	Degree of protection NEMA/UL	NEMA 2
	Enclosure	UL Enclosure Type 2
	Agency Listing	cULus acc. to UL60730-1A/-2-14, CAN/CSA E60730-1:02, CE acc. to 2014/30/EU and 2014/35/EU
	Quality Standard	ISO 9001
	Ambient temperature	-22...122°F [-30...50°C]
	Storage temperature	-40...176°F [-40...80°C]
	Ambient humidity	Max. 95% RH, non-condensing
	Servicing	maintenance-free
	Materials	Housing material

Footnotes † Use flexible metal conduit. Push the listed conduit fitting device over the actuator's cable to butt against the enclosure. Screw in conduit connector. Jacket the actuators input wiring with listed flexible conduit. Properly terminate the conduit in a suitable junction box. Rated impulse Voltage 800V. Type of action 1. Control pollution degree 3.

Accessories

Electrical accessories	Description	Type
	Auxiliary switch 2 x SPDT for NG GV Actuators	S2A-GV

Electrical installation

✂ INSTALLATION NOTES

- ◆ Meets cULus requirements without the need of an electrical ground connection.
- ▲1 Provide overload protection and disconnect as required.
- ▲2 Actuators may be connected in parallel. Power consumption and input impedance must be observed.
- ▲8 Control signal may be pulsed from either the Hot (Source) or Common (Sink) 24 V line.
- ▲11 Actuators may be connected in parallel if not mechanically linked. Power consumption and input impedance must be observed.
- ▲1B Actuators with plenum cable do not have numbers; use color codes instead.
- ▲1 **Warning! Live electrical components!**
During installation, testing, servicing and troubleshooting of this product, it may be necessary to work with live electrical components. Have a qualified licensed electrician or other individual who has been properly trained in handling live electrical components perform these tasks. Failure to follow all electrical safety precautions when exposed to live electrical components could result in death or serious injury.

Wiring diagrams

On/Off

24 VAC Transformer (AC Only)

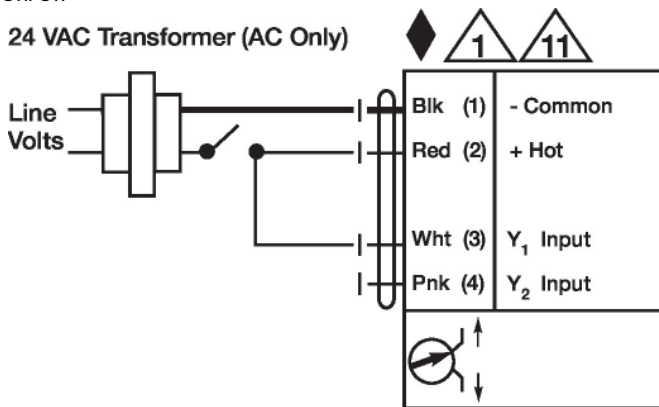

Floating Point

24 VAC Transformer (AC Only)

