



5-year warranty



Technical data

Electrical data	Nominal voltage	AC/DC 24 V	
	Nominal voltage frequency	50/60 Hz	
	Power consumption in operation	1.5 W	
	Power consumption in rest position	0.5 W	
	Power consumption for wire sizing	2.5 VA	
	Transformer sizing	1.5 VA (class 2 power source)	
	Electrical Connection	Plenum cable 18 GA, 3 ft [1 m], degree of protection NEMA 2 / IP54	
	Overload Protection	electronic throughout full rotation	
Functional data	Torque motor	18 in-lb [2 Nm]	
	Position feedback U	2...10 V	
	Position feedback U note	Max. 0.5 mA	
	Direction of motion motor	by electrical installation	
	Manual override	disengage with magnet	
	Angle of rotation	0...287.5°	
	Angle of rotation note	Without limitation: endless With one end stop clip Z-ESCM: 315°	
	Running Time (Motor)	35 s / 90°	
	Running time motor note	constant, independent of load	
	Noise level, motor	45 dB(A)	
	Shaft Diameter	1/4...1/2" round, centers on 3/8"	
	Position indication	Mechanically, pluggable (with integrated magnet for gear disengagement)	
	Safety data	Degree of protection IEC/EN	IP54
		Degree of protection NEMA/UL	NEMA 2
Enclosure		UL Enclosure Type 2	
Agency Listing		cULus acc. to UL60730-1A/-2-14, CAN/CSA E60730-1:02, CE acc. to 2014/30/EU and 2014/35/EU; Listed to UL 2043 - suitable for use in air plenums per Section 300.22(c) of the NEC and Section 602.2 of the IMC	
Quality Standard		ISO 9001	
Ambient temperature		-22...122°F [-30...50°C]	
Storage temperature		-40...176°F [-40...80°C]	
Ambient humidity		Max. 95% RH, non-condensing	
Servicing		maintenance-free	
Weight		Weight	0.60 lb [0.27 kg]
		Materials	Housing material

Footnotes †Rated Impulse Voltage 800V, Type of Action 1, Control Pollution Degree 2.

Product features

- Application** Damper actuator for operating air control dampers in ventilation and air-conditioning systems for building services installations.
- For air control dampers up to approximately 4.5 sq ft
 - Torque 18 in-lb [2 Nm]
 - Nominal voltage AC/DC 24 V
 - Control: 2...10 V
 - Running time 35 s @ 90°
- Operation** Simple direct mounting on the damper spindle with a universal spindle clamp or form fit, supplied with an anti-rotation bracket to prevent the actuator from rotating.
- Manual operation is possible with a magnet (the gearing latch remains disengaged as long as the magnet is in place).
- Adjustable angle of rotation with mechanical end stops, that requires no tools to move or remove.
- The actuator is overload-proof, requires no limit switches and automatically stops when the end stops is reached.
- The CMB24-SR (-R or -L) actuator uses a brushless DC motor, which is controlled by an Application Specific Integrated Circuit (ASIC). The ASIC monitors and controls the actuator's rotation sensing (DRS) function to prevent damage to the actuator in a stall condition. Power consumption is reduced in holding mode.
- Belimo's Halomo sensorless brushless DC motor spins by reversing the poles of stationary electromagnets housed inside rotational permanent magnets. The electromagnetic poles are switched by the an ASIC developed by Belimo. Unlike the conventional DC motor, there are no brushes to wear or commutators to foul. This means the brushless DC motor adds accuracy and reduces power consumption in a holding mode.
- Typical specification** Proportional control damper actuators shall be electronic direct-coupled type, which require no crank arm and linkage and be capable of direct mounting to a shaft from 1/4" to 1/2" diameter. Actuators must provide proportional damper control response to a 2 to 10 VDC or, with the addition of a 500Ω resistor, a 4 to 20 mA control input from an electronic controller or positioner. Actuators shall have brushless DC motor technology and be protected from overload at all angles of rotation. Actuators shall have manual override on the cover. Run time shall be constant and independent of torque. Actuators shall be cULus listed, have a 5-year warranty, and be manufactured under ISO 9001 International Quality Control Standards. Actuators shall be as manufactured by Belimo.

Electrical installation

- ⚠️ Provide overload protection and disconnect as required.
- ⚠️ Actuators may also be powered by DC 24 V.
- ⚠️ Only connect common to negative (-) leg of control circuits.
- ⚠️ A 500 Ω resistor (ZG-R01) converts the 4...20 mA control signal to 2...10 V.
- ⚠️ Actuators may be connected in parallel if not mechanically linked. Power consumption and input impedance must be observed.

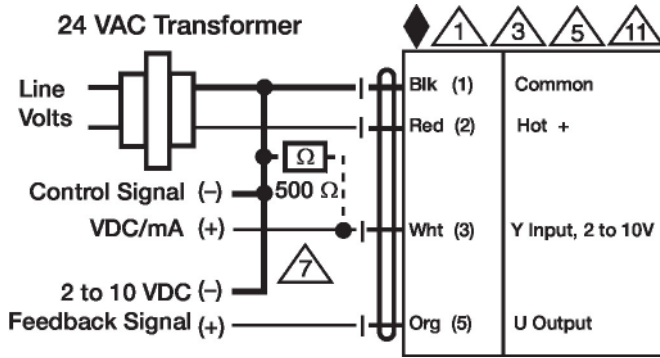

2...10 V / 4...20 mA Control

Dimensions

