

Cloud capable and communicating failsafe damper actuator for adjusting dampers in commercial HVAC applications.

- Failsafe
- Air Damper Size Up to approx. 45 sq. ft.
- Nominal Torque 180 in-lb [20 NM]
- Power Supply AC/DC 24 V
- Ethernet 10/100 Mbit/s, TCP/IP, integrated web server
- Conversion of sensor signals
- Communication via BACnet/IP, Modbus TCP and Ethernet to Belimo Cloud

Technical data

Electrical data	Power supply	24 VAC/DC, 50/60 Hz	
	Nominal voltage range	AC 19.2...28.8 V, ($\pm 20\%$) DC 21.6... 28.8 V, (-10%/+20%)	
	Power consumption, running	5.5 W	
	Power consumption, holding	5 W	
	Transformer sizing	8.5 VA (class 2 power source)	
	Electrical connections	for power and control: 3 ft [1 m], 18 GA appliance cable with 1/2" conduit connector for communication: RJ245 socket, w/boot	
	Overload protection	electronic throughout 0° to 95° degree rotation	
	Functional data	Nominal torque	min. 180 in-lb [20 NM]
		Communicative control	Cloud: (call for "clientAPI") BACnet/IP: (see "PICS" statement) Modbus TCP: (see "Modbus Register")
		Position signal 'S1'	2-10 VDC (For local hybrid control use S1)
Universal sensor Input		two universal sensor inputs (S1 and S2) <ul style="list-style-type: none"> • Contact closure • Passive, 0...50KΩ (select type and value) • Analog (Active), 0-10 or 2-10 VDC (select) 	
Feedback output U		2-10 VDC, 0.5 mA max., VDC variable	
Direction of rotation (Motor)		reversible with built-in switch	
Direction of rotation (Spring)		reversible with CW/CCW mounting	
Manual override		5 mm hex crank (3/16" Allen), supplied	
Angle of rotation		95° (adj. with mechanical end stop, 35° to 95°)	
Running time (Motor)		150 sec (default), variable (70 to 220 sec)	
Running time (Spring)	<20 sec @ -4°F to 122°F [-20°C to 50°C], < 60 sec @ -22°F [-30°C]		
Safety	Position indication	visual indicator, 0° to 95° ('0' is return position)	
	Protection class IEC/EN	III safety extra-low voltage (selv)	
	Housing	NEMA 1	
	Housing material	zinc coated metal and plastic casing	
	Rated voltage supply / control	0.8 kV	
	Ambient temperature range	-22°F to 122°F [-30°C to 50°C]	
	Storage temperature range	-40°F to 176°F [-40°C to 80°C]	
	Humidity	5 to 95% RH non condensing (EN 60730-1)	
	Agency listings	cULus acc. to UL 60730-1A/-2-14, CAN/CSA E60730-1:02, CE acc. to 2004/108/EEC and 2006/95/EC	
	Noise level (Motor)	≤ 40 dB (A) @ 150 sec, run time dependent	
Noise level (Spring)	<62 dB (A)		
Servicing	maintenance free		
Quality standard	ISO 9001		
Weight	Weight	4.6 lbs [2.1 kg]	

Product Features

Application	For failsafe modulation of dampers in HVAC systems. Actuator sizing should be in accordance with the damper manufactures specifications. The actuator is controlled via the Belimo Cloud, BACnet/IP or Modbus TCP and drives to the position defined by the control variable. Multiple data points can be written and read via the control interface. Local control mode: The actuator receives an analog control signal from a conventional controller and drives to the control position. In addition, using the Belimo Cloud, BACnet/IP or Modbus TCP, various data points can be read and with the exception of the control signal written to the actuator. This Belimo Cloud connected damper actuator has two universal sensor inputs ready for your innovative HVAC applications. The two universal sensor inputs (passive, active, or contact) serve as an analog/digital converter for the digital transmission of the sensor value to a higher level system. Selecting the sensor type is accomplished via connection to the integrated web server (RJ45 connection to the web browser) or directly via the Belimo Cloud. The actuators performance and sensor data is recorded locally with 13 months of storage. This data can be used for analytical purposes, downloaded via csv files, or used in your HVAC application.
Operation	The AFB actuators use a brushless DC motor, which is controlled by an Application Specific Integrated Circuit (ASIC). The ASIC monitors and controls the actuator's rotation and provides a digital rotation sensing (DRS) function to prevent damage to the actuator in a stall condition. Power consumption is reduced in holding mode. The actuator is not provided with and does not require any limit switches, but is electronically protected against overload. The AFB series provides 95° of rotation and a visual indicator scale indicates position of the actuator. When reaching the damper or actuator end position, the actuator automatically stops. The anti-rotation strap supplied with the actuator will prevent lateral movement.
Direct mounting	Simple direct mounting on the damper spindle with a universal spindle clamp, supplied with an anti-rotation strap to prevent the actuator from rotating.
Converter for sensors	Connection option for two sensors (passive, active, or contact). The actuator serves as an analogue/digital converter for the transmission of the sensor signal to the higher level system.
Communication	The parameterization can be carried out through the integrated web server (RJ45 connection to the web browser), by communicative means or via the Cloud. Additional information regarding the integrated web server can be found in the separate documentation.
Position signal inversion	Signal inversion in cases of control with an analogue positioning signal. The inversion causes the reversal of the standard behavior, i.e. for control signal 0%, the actuator is opened to Max and for control signal 100%, the actuator would close.
Data recording	The recorded data (integrated data recording for 13 months) can be used for analytical purposes. Download the csv files via the built-in web browser.
Manual override	A unique manual override allows the setting of any actuator position within its 95° of rotation with no power applied. This mechanism can be released physically by the use of a crank supplied with the actuator. When power is applied the manual override is released and the actuator drives toward the fail-safe position. The AFB actuator is shipped at 5° (5° from full fail-safe) to provide automatic compression against damper gaskets for tight shut-off.
Adjustable angle of rotation	Adjustable angle of rotation with mechanical end stops.
High functional reliability	The actuator is overload protected, requires no limit switches and automatically stops when the end stop is reached.
Home position	The first time the supply voltage is switched on, i.e. at the time of commissioning, the actuator carries out an adaption, which is when the operating range and position feedback adjust themselves to the mechanical setting range. The actuator then moves into the position defined by the direction of rotation switch and desired positioning signal.

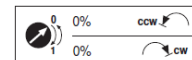

Electrical installation

Notes

- Connection via class 2 transformer.
- Parallel connection of additional actuators is possible (power and control).
- Limit of **ONE** actuator per control shaft!



Additional notes

1. Provide overload protection and disconnect as required.
2. CAUTION Equipment Damage! Actuators may be connected in parallel if not mechanically mounted to the same shaft. Power consumption and input impedance must be observed.
3. Actuators may also be powered by 24 VDC.
4. Additional actuators may be wired in parallel. Ensure sufficient power supply VA is available.
5. For “Local Control” via 2-10VDC the S1 sensor must be used and configured as ‘Active Sensor’.
6. Connection to Intranet / Internet via RJ45 socket
7. Connection of a notebook for initial parameterization and/or manual control via RJ45 connection. Optional direct connection via RJ45 for direct access to integrated webserver and stored data.
8. “Not Used”: All cable conductors that are not used must be isolated from surrounding surfaces, by wire nut, electrical tape, or other method.

Wiring diagrams

Initial Ethernet Connection and Set-up

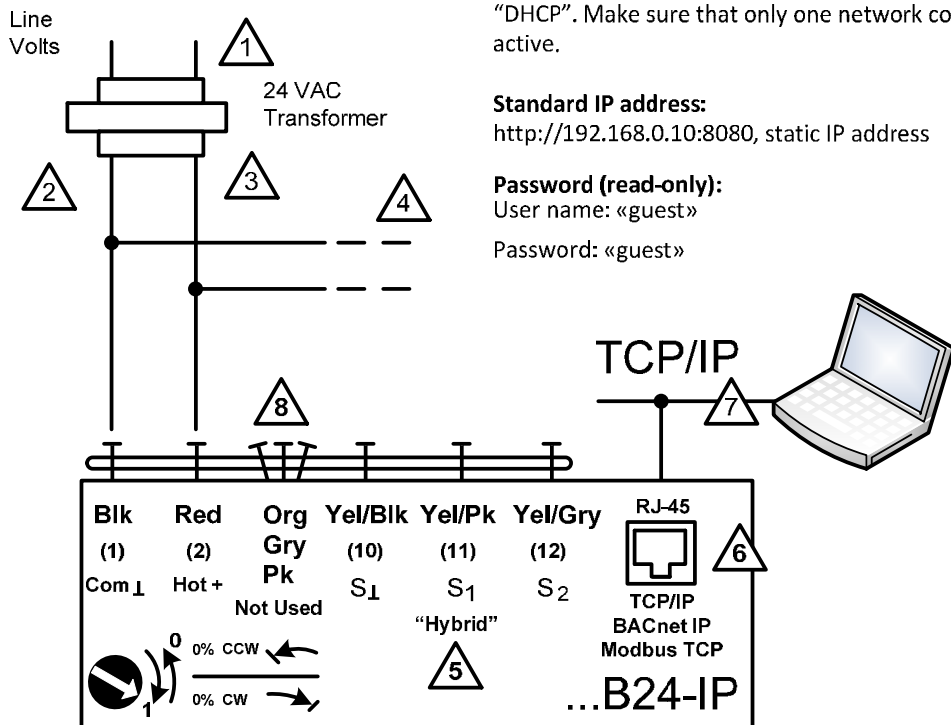

“Peer to Peer” connection:

<http://belimo.local:8080>, the Notebook must be set to “DHCP”. Make sure that only one network connection is active.

Standard IP address:

<http://192.168.0.10:8080>, static IP address

Password (read-only):

User name: «guest»

Password: «guest»

Electrical installation

Notes

- Connection via class 2 transformer.
- Parallel connection of additional actuators is possible (power and control).
- Limit of **ONE** actuator per control shaft!
- The wiring diagrams show connections for the first sensor on terminal S1, while the second sensor can be identically on terminal S2.
- Different sensor types can be used with each sensor input. For example, active 2-10 on S1 and NTC1000 on S2.
- For “hybrid” operation, analog input and digital communication, S1 is used as the analog input and must be configured as ‘active sensor’.

Additional notes



1. Provide overload protection and disconnect as required.
2. CAUTION Equipment Damage! Actuators may be connected in parallel if not mechanically mounted to the same shaft. Power consumption and input impedance must be observed.
3. Actuators may also be powered by 24 VDC.
4. Additional actuators may be wired in parallel. Ensure sufficient power supply VA is available.
5. For “Local Control” via 2-10VDC the S1 sensor must be used and configured as ‘Active Sensor’.
6. Connection to Intranet / Internet via RJ45 socket
7. Connection of a notebook for initial parameterization and/or manual control via RJ45 connection. Optional direct connection via RJ45 for direct access to integrated webserver and stored data.
8. Addition of sensors is optional.
9. Configure the actuator sensor input according to the sensor type and value. The connections for the first sensor on terminal S1, while the second sensor can be connected identically on terminal S2. Simultaneous use of different sensor types is possible. For example: a contact closure on S1 and a VDC sensor on S2.
10. “Not Used”: All cable conductors that are not used must be isolated from surrounding surfaces, by wire nut, electrical tape, or other method.

Local analog control or analog override with Belimo Cloud (TCP/IP), BACnet IP, or Modbus TCP connection.

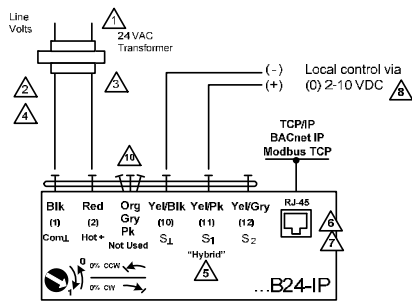

Connection of contact closure sensor

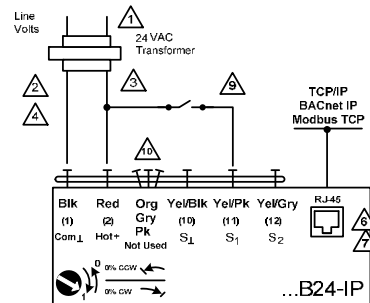

Connection of passive sensor

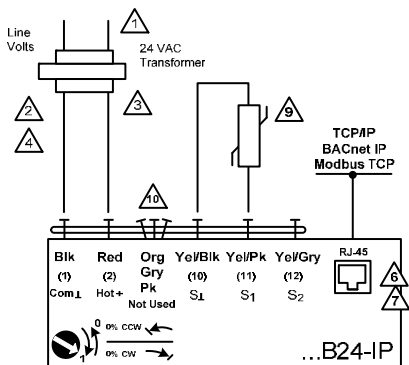

Connection of active sensor

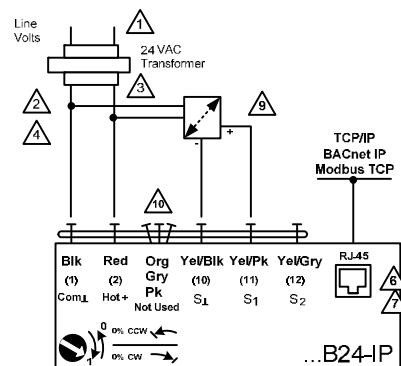

Mxxx - 04/18 - SUBJECT TO CHANGE. © Belimo Aircontrols (USA), Inc.

Feature overview

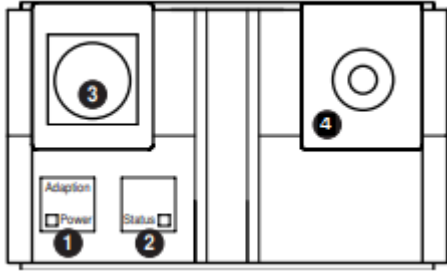

1. LED display, green
 Off: No power supply or wiring error
 On: In operation
 Press button: Triggers an angle of rotation adaption, then standard mode.
2. Push button LED display, orange
 Off: Standard mode
 On: Adaption or synchronization active
 Press button: No function
3. RJ45 socket
 For connection of TCP/IP (Cloud), BACnet/IP, and Modbus TCP
4. Power and control cable

Dimensions (inch [mm])

Shaft length

		Min. 3.35" [85]
		Min. 0.59" [15]

Clamping range

1/2" ... 1.05" [12 ... 20 mm]	.39" [>10mm]	<3/4" [20mm]

Dimensions

