

# FIREYE M4RT24

Low Voltage

FLAME SAFEGUARD CONTROLS



**WARNING:** Selection of this control for a particular application should be made by a competent professional, licensed by a state or other government agency. Inappropriate application of this product could result in an unsafe condition hazardous to life and property.

## DESCRIPTION

The Fireeye® M4RT24 Flame Safeguard Control is a compact burner management system for low voltage (24V AC/DC) applications. It is designed to provide automatic ignition and flame monitoring for commercial sizes for heating and process burners that use gaseous or liquid fuels. Flame monitoring is accomplished by an Ultra-Violet (UV) detector or Flame Rod (FR), with the built in amplifier and programmer. Control functions and timings such as recycle/non-recycle, purge timing, and pilot trial for ignition (PTFI) time are pre-configured at the factory, and are determined by part number (e.g. M4RT24-17). Flame Failure Response Time (FFRT) is fixed at 4 seconds. LED indicator lights indicate the operating status of the control.

In the event of ignition failure, following a safety shutdown, the unit locks out, activating an alarm circuit. Available remote reset terminals can be used to reset the control from a lockout state. A detailed description of the programmer sequence is found later in this document. Test jacks are provided to permit flame signal strength measurement during operation.

The M4RT24 control incorporates a safety circuit that is operative on each start. If flame (real or simulated), is detected prior to a start or during the purge, the fuel valves will not be energized, and the unit will lockout. A proof of closure (POC) input could be used as an additional safety to monitor the main fuel shutoff valves during burner startup.

All M4RT24 controls do not require a wiring base due to the available terminal blocks for easy connectivity. See INSTALLATION OF CONTROL, SCANNERS, AND FLAME DETECTORS (page 5) for temperature and wiring requirements.



## SPECIFICATIONS

**Supply:**  
24V (DC or AC) (+10%, -15%)

**Table 1: AMBIENT TEMPERATURE LIMITS**

	MAXIMUM		MINIMUM	
M4RT24 Control	+140°F	+60°C	- 40°F	- 40°C
UV90L-2 Scanner	+194°F	+90°C	- 40°F	- 40°C

**Power Consumption:** 6 Watts (Operating)

**Shipping Weight (Approx.):** 2 lbs. (0.9kg)

**Table 2: LOAD RATINGS**

Fireye Terminal	Typical Load	Rating
P5.1, P5.3	Pilot valve Ignition Transformer	75VA
P5.2	Main Fuel Valve	100VA
P5.5	Motor or contactor	4 F.L.A., 8 L.R.A.
P5.7	Alarm	25VA
Minimum load requirement = 100mA F.L.A. = Full Load Amps; L.R.A. = Locked Rotor Amps		

## APPROVALS

**Underwriters Laboratories Inc.**

**File: MCCZ7.MP1537 and MCCZ.MP1537**

## ORDERING INFORMATION

### CONTROL:

M4RT24-17 Control, 24V (AC/DC), 5sec Purge, 5sec PTFI, recycle operation

M4RT24-33 Control, 24V (AC/DC), 5sec Purge, 10sec PTFI, Non-recycle operation, 4sec FFRT

M4RT24-35 Control, 24V (AC/DC), 35sec Purge, 10sec PTFI, Non-recycle operation, 4sec FFRT

**NOTE:** Please consult factory for other timing options.

### FLAME DETECTORS:

UV90L-2 UV scanner, front and side (90°) lateral view, terminal block hook-up

69ND1-1000K4 Flame rod 1/2" NPT Mount, 12" Length

69ND1-1000K6 Flame rod 1/2" NPT Mount, 18" Length

69ND1-1000K8 Flame rod 1/2" NPT Mount, 24" Length

**Table 3: TERMINAL WIRING**

Terminal No.	Type	Description	Rating
P5.1	Output	Ignition	24V AC/DC, see load ratings
P5.2	Output	Main Fuel Valve	24V AC/DC, see load ratings
P5.3	Output	Pilot Valve	24V AC/DC, see load ratings
P5.4	Input	Recycle / Airflow	24V AC/DC
P5.5	Output	Blower	24V AC/DC, see load ratings
P5.6	Input	Running/Safety Interlock	24V AC/DC, up to 15A
P5.7	Output	Alarm	24V AC/DC, see load ratings
P5.8	Input	Proof of Closure (FVES)	24V AC/DC, 50mA
P5.9	Input	24V Return	Power Supply Ground
P5.10	Input	Earth	Earth Ground
P6.1	Input	UV Scanner (-)	UV Scanner Excitation
P6.2	Input	UV Scanner (+)	
P6.3	Input	Flame Rod	Flame Rod Excitation



**WARNING:** Failure to properly install, operate, or commission the equipment in this manual could result in significant property damage, severe injury, or death. It is the responsibility of the owner or user to ensure that the equipment described is installed, operated and commissioned in compliance with this manual and other system component manuals, as well with all applicable national and local codes.



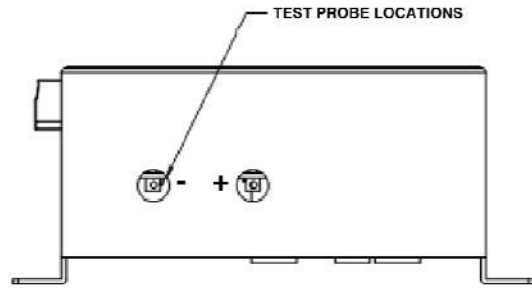
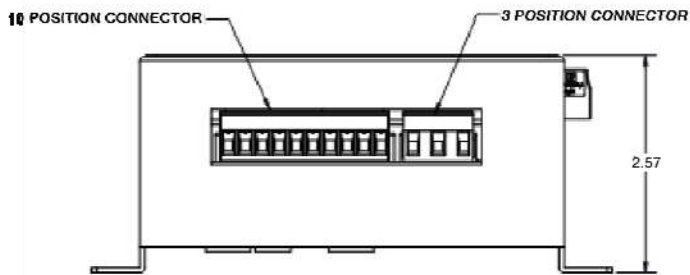
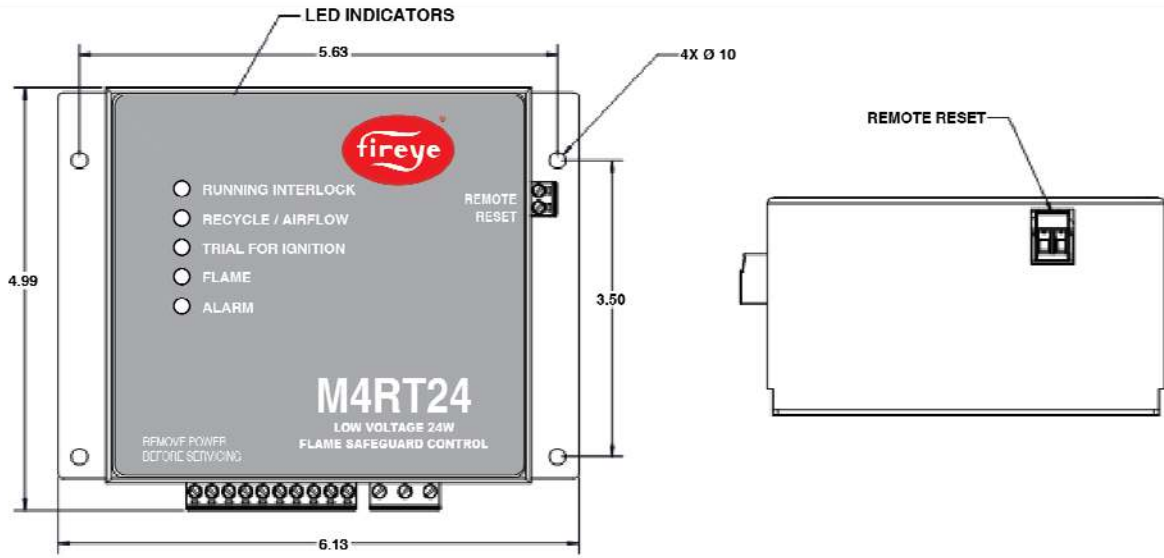
**!!!WARNING!!!**



Boiler operation, maintenance, and troubleshooting shall only be conducted by trained personnel. Persons troubleshooting lockouts or resetting the control must respond properly to troubleshooting error codes as described in this product bulletin.

Jumpers being used to perform static test on the system must only be used in a controlled manner and must be removed prior to the operation of the control. Such tests may verify the external controllers, limits, interlocks, actuators, valves, transformers, motors and other devices are operating properly. Such tests must be conducted with manual fuel valves in the closed position only. Replace all limits and interlocks not operating properly, and do not bypass limits in interlocks. Failure to follow these guidelines may result in an unsafe condition hazardous to life and property.

## MECHANICALS





---

## INSTALLATION OF CONTROL, SCANNERS, AND FLAME DETECTORS

### Mounting and wiring the control

Mount the control in an enclosure/burner panel that provides the proper protection for the control. The location should be free from moisture, excessive vibration, and within the specified ambient temperature rating. The control may be mounted in any angular position.

All wiring should comply with applicable electrical codes, regulations, and local ordinances. Use moisture resistant wire suitable for at least 90°C. Circuit recommendations are found on pages 9 through 10. Consult the factory for assistance with non-standard applications.



**WARNING: Installer must be trained and qualified. Follow the burner manufacturer's instructions, if supplied. Otherwise, proceed as follows.**

**WARNING: Controls require safety limits utilizing isolated mechanical contacts. Solid state limit switches are not acceptable and should not be used due to their high leakage currents.**

**WARNING: Remove power from the control before proceeding.**

### Replaceable Fuse

The M4RT24 is designed with two field replaceable fuses. The fuses are located on the printed circuit board. The fuse(s) will blow as a result of an overload condition on Terminal P5.1, P5.2, P5.3, P5.5 or P5.7. Fuse F1 protects P5.1 (Ignition), P5.2 (Main Fuel Valve), P5.3 (Pilot Valve) and P5.7 (Alarm). Fuse F2 protects P5.5 (Blower). To replace the fuse, remove power from the system. Unmount the control from the sub-plate. With the aid of a small screwdriver or similar tool, remove the fuse from its holder. Install a Fireeye replacement fuse (P/N 23-246) or equivalent fuse (e.g. Littelfuse 37315300410, 6.3A, 125V).



**WARNING: Turn off the power when installing or servicing the control.**

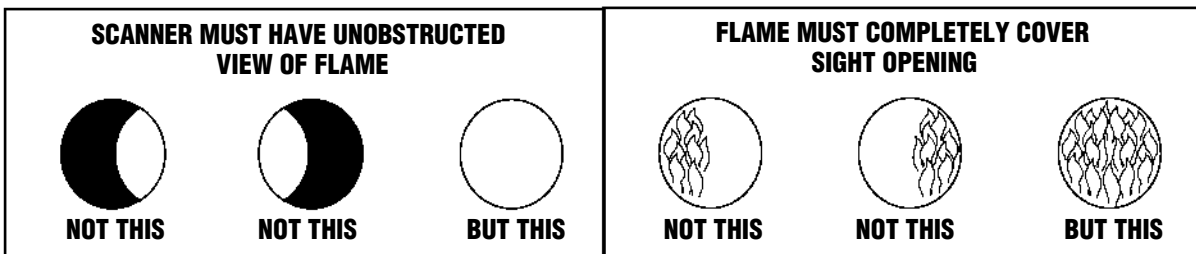
## INSTALLATION - UV Scanners



### INSTALLATION - UV SCANNERS

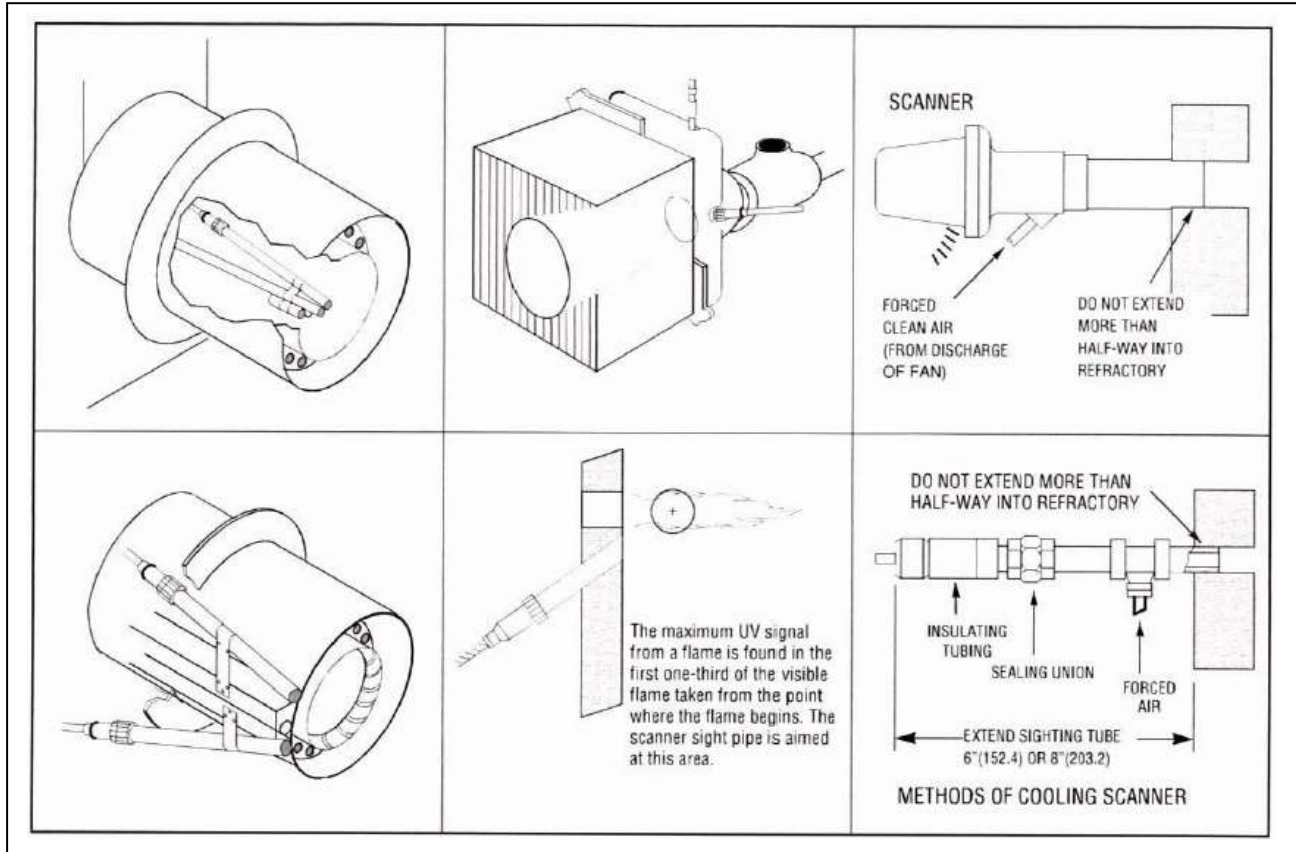
Where possible, obtain the burner manufacturer's instructions for mounting the scanner. This information is available for most standard burners. The scanner mounting should comply with the following general instructions:

1. Position the scanner within 39 inches (1 meter) of the flame to be monitored.
2. Select a scanner location that remains within the ambient temperature limits of the UV scanner.



3. If the scanner mounting pipe sights through the refractory, do not extend it more than halfway through. The sight pipe must permit an unobstructed view of the pilot and/or main flame, and both pilot and main flames must completely cover the scanner field of view.
4. Smoke or unburned combustion gases absorb ultra-violet energy. On installations with negative pressure combustion chambers, a small hole drilled in the sight pipe assists in keeping the pipe clean and free from smoke. For positive pressure furnaces, provide clean air to pressurize the sight pipe, if necessary.
5. Two UV90L-2 scanners may be installed on the burner if it is necessary to view two areas to obtain reliable detection of the flame. They must be wired in parallel.
6. Request the assistance of any Fireeye field office for recommendations of a proper scanner installation on a non-standard application.

## TYPICAL SCANNER INSTALLATIONS



## WIRING - UV SCANNERS

The UV90L-2 is supplied with a terminal board. Use two #20 AWG conductors rated for 90° C, 600V to connect the UV90L-2 to the control.

There is polarity associated with the UV scanner wiring. Connect the “+” terminal to P6.2 and the “-” terminal to P6.1. Scanner wires must be installed in a separate conduit. The wires from several scanners may be installed in a common conduit.

1. Selection of Wire
  - a. Wiring: For extended scanner wiring up to 500 feet (152 M), and for shorter lengths to reduce signal loss, use a shielded wire (Belden 8254-RG62 coaxial cable, or equal) for each scanner wire. The ends of the shielding must be taped and not grounded.
  - b. Avoid asbestos insulated wire.
  - c. Multi-conductor cable is not recommended without prior factory approval.
2. High voltage ignition wiring must not be installed in the same conduit with flame detector wires.



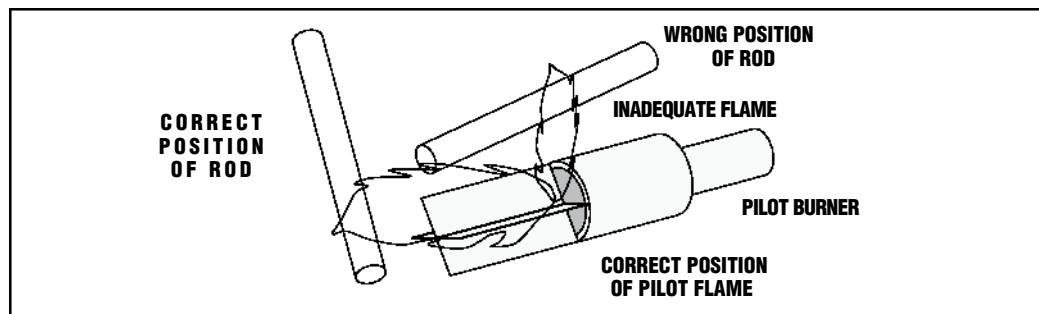
## INSTALLATION - 69ND1 FLAME ROD

The 69ND1 flame rod proves a gas pilot flame and/or main gas flame. It is a *spark plug* type unit consisting of  $\frac{1}{2}$ " NPT mount, a KANTHAL flame rod, a glazed porcelain insulating rod holder and a spark plug connector for making electrical connections. The 69ND1 is available in 12," 18" or 24" lengths.

The flame rod may be located to monitor only the gas pilot flame or both the gas pilot and main gas flames. It is mounted on a  $\frac{1}{2}$ " NPT coupling.

The following instructions should be observed:

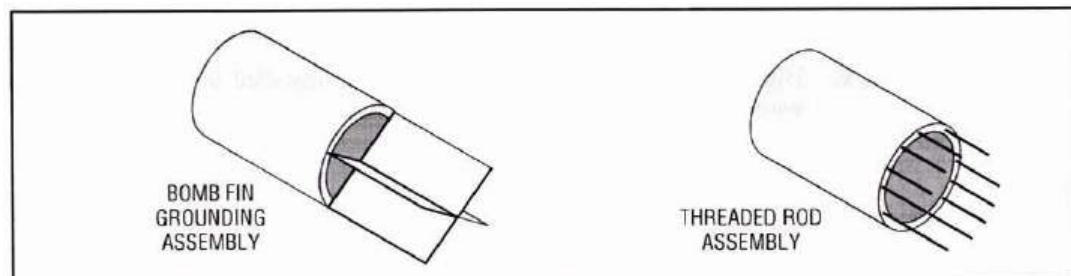
1. Keep flame rod as short as possible.
2. Keep flame rod at least  $\frac{1}{2}$ " from any refractory.
3. Flame rod should enter the pilot flame from the side so as to safely prove an adequate pilot flame under all draft conditions.
4. If the flame is nonluminous (air and gas mixed before burning), the electrode tip should extend at least  $\frac{1}{2}$ " into the flame, but not more than halfway through.



5. If the flame is partly luminous, the electrode tip should extend only to the edge of the flame. It is not necessary to maintain absolutely uninterrupted contact with the flame.
6. It is preferable to angle the rod downward to minimize the effect of sagging and to prevent it from coming in contact with any object.
7. An adequate grounding surface for the flame must be provided. The grounding surface in actual contact with the flame must be at least four times greater than the area of the portion of the flame rod in contact with the flame. It is essential to adjust the flame rod and ground area ratio to provide a minimum signal reading of 6.0 VDC.

*Note: Interference from the ignition spark can alter the true signal reading by adding to, or subtracting from it. This trend sometimes may be reversed by interchanging the primary wires (line voltage) to the ignition transformer. This interference can also be reduced by the addition of grounded shielding between the flame rod and ignition spark.*

8. Proven types of flame grounding adapters, as shown below, may be used to provide adequate grounding surface. High temperature stainless steel should be used to minimize the effect of metal oxidation. This assembly may be welded directly over the pilot or main burner nozzle.







---

## WIRING OF FLAME RODS

For proper operation of flame rectification systems, it is necessary to maintain at least 20 megohms insulating resistance in the flame rectification circuit.

1. The scanner should be wired using metal cable or rigid conduit.
2. High voltage wiring must not be installed in the same conduit with scanner wiring.

### Selection of Scanner Wire

1. Use #18, 20, or 22 gauge wire with 90° C, 600 volt insulation for up to 20 feet distance.
2. The type of insulation used with flame rectification is important, since it must protect against current leakage resistance to ground. Use Belden 8254-RG62 Coaxial Cable (or equal) for runs greater than 20 feet. **Maximum wiring run not to exceed 100 feet.**

---

## MAINTENANCE

### UV Scanner

The UV scanner should be periodically checked for faulty or runaway condition. With the system in standby, manually shutoff the main fuel supply. Run the system and make sure that the control does not detect a flame or the scanner is not “firing.”

### 69ND1 Flame Rod

The flame rod and its insulator should be kept clean by washing routinely with soap and water. Rods should be routinely replaced as they oxidize.

### Flame Signal Strength

Routine observation of the flame signal strength will forewarn any deterioration in the capability of the flame detector or its application.

### Periodic Safety

It is recommended that a procedure be established to test the complete flame safeguard system at least once a month. This test should verify the proper operation of all limit switches and safety interlocks as well as flame failure protection and fuel safety shutoff valve tightness.

---

## RESET

In the event of a lockout condition, the M4RT24 can be reset via the remote reset terminals. Using those terminals, a remote, dry contact pushbutton switch can be connected. The maximum wire length is 100 feet (no.18 AWG wire size is recommended).



**CAUTION:** Remote reset is recommended only on a control solely for proved ignition programming (pilot ignited burner) or a control for use only with appliances in which unburned fuel cannot accumulate and that is intended for installation in inaccessible locations such as open-flame, ceiling-suspended gas heaters.



**WARNING:** When choosing a model of the M4RT24, selection of the Purge time and Recycle / Non-Recycle operation for a particular application, should only be performed by a competent professional, licensed by a state or other government agency. Inappropriate selection of these safety critical parameters could result in an unsafe condition hazardous to life and property.



---

## LED INDICATOR LIGHTS

The M4RT24 has 5 LED lights to indicate the operating status of the control. The function of these lights are:

**RUNNING INTERLOCK:** This LED is activated whenever input Terminal P5.6 is energized and after Terminal P5.8 has been energized. The burner system safety interlocks should be wired in series and connected to the M4RT24 Terminal P5.6 (Running/Safety interlock).

**RECYCLE/AIRFLOW:** This LED is lit whenever all of these conditions exist:

- Input Terminal P5.6 is energized (operating control and safety interlocks closed).
- Input Terminal P5.4 is energized (proof of airflow switch is closed).
- Output Terminal P5.5 is energized (blower motor).

**TRIAL FOR IGNITION:** This LED is activated only during the Pilot Trial for Ignition Period.

**FLAME:** This LED is activated whenever an adequate flame signal is detected between the M4RT24 Terminals P6.1 & P6.2 (UV scanner) or P6.3 & Earth (Flame rod). It should be noted that the LED is also activated whenever there is false flame condition.

**ALARM:** This LED is energized whenever a safety lockout occurs. (See APPLICATION AND FUNCTION section).

*NOTE: The M4RT24 is not powered until the user's operating control is energized and both Terminals P5.6 and P5.8 are energized.*

---

## APPLICATION AND FUNCTION

The M4RT24 provides prepurge, ignition and flame safeguard for heating and process gas fired burners. The “recycle” or “non-recycle” operation is configured at the factory. Purge times and trial for ignition times are also set at the factory.

The M4RT24 amplifier circuitry is designed to utilize a UV Scanner or Flame Rod for flame detection. The Flame Failure Response Time (FFRT) is fixed at 4 seconds.

### Pilot Ignited Burners - “Recycle” Operation

When configured for recycle, the typical wiring arrangement illustrated on page 15 for pilot ignited burners provides the following function:

1. With power applied to Terminals P5.6 (Running Interlock) and P5.8 (Proof of Closure), the burner motor circuit (Terminal P5.5) is energized. The control then waits for the proof of airflow input (Terminal P5.4) to be energized
2. The Pre-purge timing starts when Terminal P5.4 is energized.
3. Following the prepurge period, KL-1 closes, energizing Terminal P5.3 which powers the pilot gas valve and Terminal P5.1 which powers the spark ignition. A five or ten sec. (based on configuration) trial for ignition is initiated (**Trial for Ignition** LED lit).
4. When pilot flame is detected (**Flame** LED lit), KF-1 closes, energizing Terminal P5.2 which powers the main fuel valve, KF-2 opens de-energizing Terminal P5.1 which shuts off the spark ignition.
5. When the operating control opens its circuit, or if a power failure occurs, the entire system is de-energized. Power interruptions in the millisecond range do not affect the operation of the control. Power interruptions of longer duration will cause the control to recycle.
6. In the event the pilot flame is not detected by the end of trial for ignition period (TFI), the pilot gas valve (Terminal P5.3) and spark ignition (Terminal P5.1) are de-energized. A safety shutdown occurs followed in approximately 30 seconds by a safety lockout that de-energizes the blower motor (Terminal P5.5) and energizes the lockout alarm circuit (Alarm LED lit).
7. In the event of a flame failure during a firing period, the pilot and main fuel valves are de-energized. Following the prepurge period, with proven air flow (AirFlow LED lit), the pilot gas valve and spark ignition are re-energized and a five or ten sec. (based on configuration) trial for ignition is initiated (TFI LED lit). If pilot flame is detected (Flame LED lit), the main fuel valve



is energized, the spark ignition is de-energized. In the event the pilot flame is not detected by the end of trial for ignition period (TFI), the pilot gas valve (Terminal P5.3) and spark ignition (Terminal P5.1) are de-energized. A safety shutdown occurs followed in approximately 30 seconds by a safety lockout that de-energizes the blower motor (Terminal P5.5) and energizes the lockout alarm circuit (Alarm LED lit).

8. Remote Reset is required following any safety lockout.

*NOTE: Wait 10 seconds after lockout before restarting the control.*

### **Pilot Ignited Burners - “Non-recycle” Operation**

The function of “non-recycle” pilot ignited burners is the same as described for the “recycle” controls, except that the “non-recycle” operation will lockout following any flame failure. “Recycle” or “non-recycle” operation is configured at the factory.

### **Direct Spark Ignited Burners - “Recycle” Operation**

The typical wiring arrangement illustrated on pages 15 for direct spark ignited burners provides the following functions:

1. With power applied to Terminal P5.6 (Running Interlock) and Terminal P5.8 (Proof of Closure), the burner motor circuit (Terminal P5.5) is energized. The control then waits for the proof of airflow input (Terminal P5.4) to be energized.
2. The Pre-Purge timing starts when Terminal P5.4 is energized.
3. Following the selected prepurge period, KL-1 closes, energizing Terminal P5.3 which powers the primary main fuel valve, and Terminal P5.1 which powers the spark ignition. A five or ten second (based on factory configuration) trial for ignition is initiated (**TFI** LED lit).
4. When pilot flame is detected (**Flame** LED lit), KF-1 closes, energizing Terminal P5.2 which powers the secondary main fuel valve, and KF-2 opens, de-energizing Terminal P5.1 which shuts off the spark ignition.
5. When the operating control opens its circuit, or if a power failure occurs, the control is de-energized. Power interruptions in the millisecond range do not affect the operation of the control. Power interruptions at longer duration will cause the control to recycle.
6. In the event the pilot flame is not detected by the end of trial for ignition period (PTFI), the pilot gas valve (Terminal P5.3) and spark ignition (Terminal P5.1) are de-energized. A safety shutdown occurs followed in approximately 30 seconds by a safety lockout that de-energizes the blower motor (Terminal P5.5) and energizes the lockout alarm circuit (Alarm LED lit).

### **Direct Spark Ignited Burners - “Non-recycle” Operation**

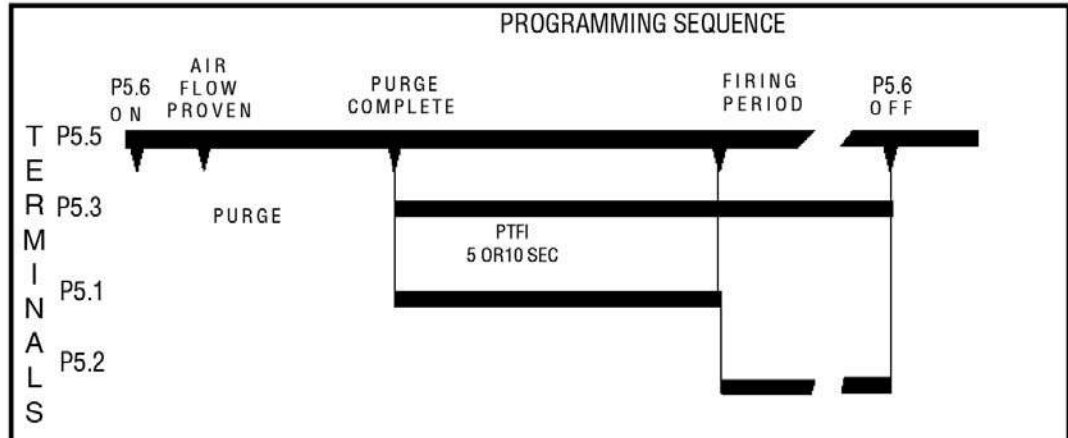
The function of “non-recycle” direct spark ignited burners is the same as described for the “recycle” controls, except that the “non-recycle” operation will lockout following any flame failure. “Recycle” or “non-recycle” operation is pre-configured at the factory.

### **Proof Of Closure (POC) Operation**

The POC input (Terminal P5.8) is intended for burner safe start -- thus proving that the fuel safety shutoff valves are in the closed position before a burner cycle commences. The control will not start a burner cycle if the POC input is not active at standby. If the feature is not required, tie POC input to +24Vinput supply. Please consult the appropriate codes or regulations concerning the requirements for proof of valve closure.



## TIMING CHART



Recycle/Non-Recycle operation on loss of flame after Terminal P5.2 energized. Recycle on loss of airflow after flame proven.

## INSTALLATION TESTING

### Use of Test Meter

Testing the Fireeye M4RT24 Control requires the use of a test AC-DC multimeter, with a 1,000 ohm/volt DC rating or greater, or a digital meter with 500K input impedance or greater.

With the test meter on the DC scale, and the test meter leads inserted into the test jacks. A **steady** DC voltage reading of **8 to 10 volts** should be obtained when the control is detecting a strong flame, **4 to 8 volts** indicates an acceptable flame, and **2 to 4 volts** indicates a weak flame.

**NOTE:** UV5-1 scanner produces a smaller dynamic range for flame signal output. With the UV5-1 scanner connected, a steady DC voltage reading of **3 volts** should be obtained when the control is detecting a strong flame, **2 to 3 volts** indicates an acceptable flame, and below **2 volts** indicates a weak flame.

### Normal Pilot Flame Test

**CAUTION:** Before making a pilot flame test, manually shut off the fuel supply to the main burner.

1. Observe the pilot flame signal on the meter. If the average signal is below the minimum of 4VDC, readjust the pilot flame or realign the flame detector.
2. During the pilot flame test, if flame is not detected within the PTFI timing window, the control will lockout. To re-establish the pilot flame trial for ignition (PTFI), manual reset of the lockout is required, and a complete prepurge accomplished.
3. When UV flame detection is used, a test is required to verify that UV radiation from the ignition spark is not being detected. To accomplish this, manually shut off both pilot and main fuels. Initiate a normal start-up, and when the PTFI sequence is on, observe the meter which should read no signal greater than 1.0VDC. If more than 1.0VDC is observed, realign the UV scanner, and/ or shield the spark from the scanner's view.
4. With all methods of flame detection, verify pilot flame failure response by manually shutting off the pilot fuel and then initiate a normal start-up. With no pilot flame present, the control will de-energize the pilot assembly at the end of the trial for ignition interval, and the control will lockout. Also, to verify that the ignition spark does not "give" a flame signal on UV or flame rod applications.



### Normal Main Flame Test

1. Manually shut off the main fuel valve for a pilot ignited burner, or the secondary fuel valve for a direct spark ignited burner.
2. Set the test meter on the DC scale and insert the test leads into the test jacks on the amplifier module. (If the meter reads backwards, reverse the meter leads). Red - Plus, Black - Negative.
3. Initiate a normal startup.
4. When the main flame is established, the test reading should be normal: a steady DC voltage reading of **2 to 10 volts**.
5. Inadequate flame signal may be improved by:
  - a Assuring that the flame detector and wiring installations have followed the instructions on pages 4 through 8.
  - b Assuring that the flame detector is clean and within the ambient temperature limits.
  - c Assuring that the flame is sufficiently large to detect.
  - d Assuring that the flame quality (fuel to air ratio, combustion air velocity) is satisfactory.

### Minimum Pilot Test

This test insures that the flame detector will not sense a pilot flame too small to light the main flame reliably. It must be made on every new installation as well as following the repositioning of the flame detector. **This procedure should not be used on a direct spark ignited burner.**

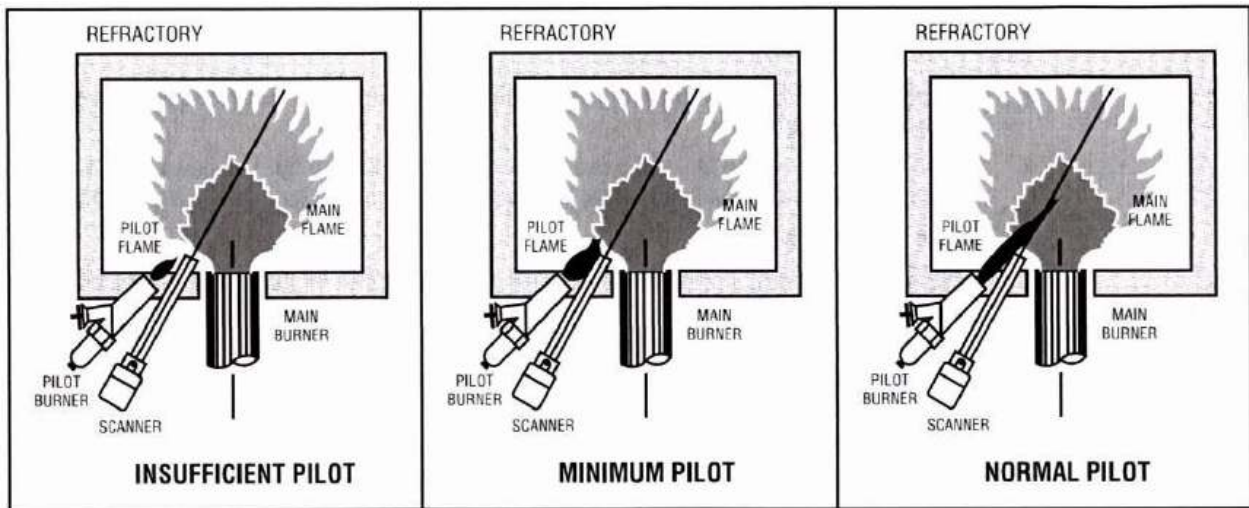
1. Manually shut off the fuel to the main burner.
2. Connect a test meter to the test jacks.
3. Initiate a normal startup.
4. Reduce the fuel to the pilot until the DC voltmeter reads approximately 6 volts or when the pilot is at the minimum to provide a reliable main flame light-off. See WARNING below. This is the minimum pilot.
5. Slowly turn on the main fuel and insure that the main flame lights off promptly and normally.



**WARNING: If light-off is delayed, shut off the power to the installation. Realign the flame detector so that pilot flame detection sees a larger pilot flame. Repeat this test until the main flame lights reliably with minimum pilot.**

**WARNING: The minimum pilot test must be accomplished by a trained and qualified burner technician.**

6. After the minimum pilot test is completed satisfactorily, increase the pilot flame to normal size, and observe that the main flame is properly established during a normal cycle.

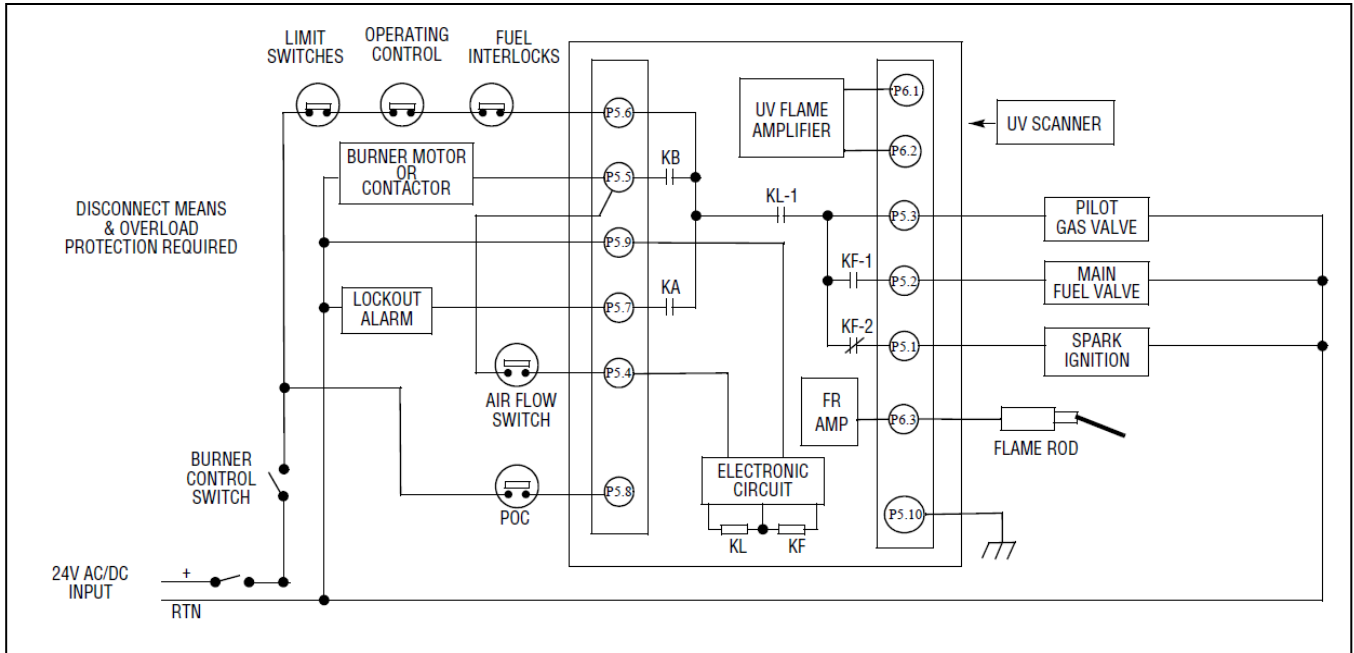


### Flame Failure Test

1. Temporarily connect spark ignition and pilot valve to Terminal P5.3.
2. Initiate a normal startup.
3. Manually shut off all fuel and observe the loss of flame signal on the test meter.
4. If flame signal does not reduce to zero within the flame failure response time of the control, inspect the flame scanner for potential “run-away” situation.
5. **IMPORTANT:** When the test is completed, reconnect the spark ignition to Terminal P5.1.

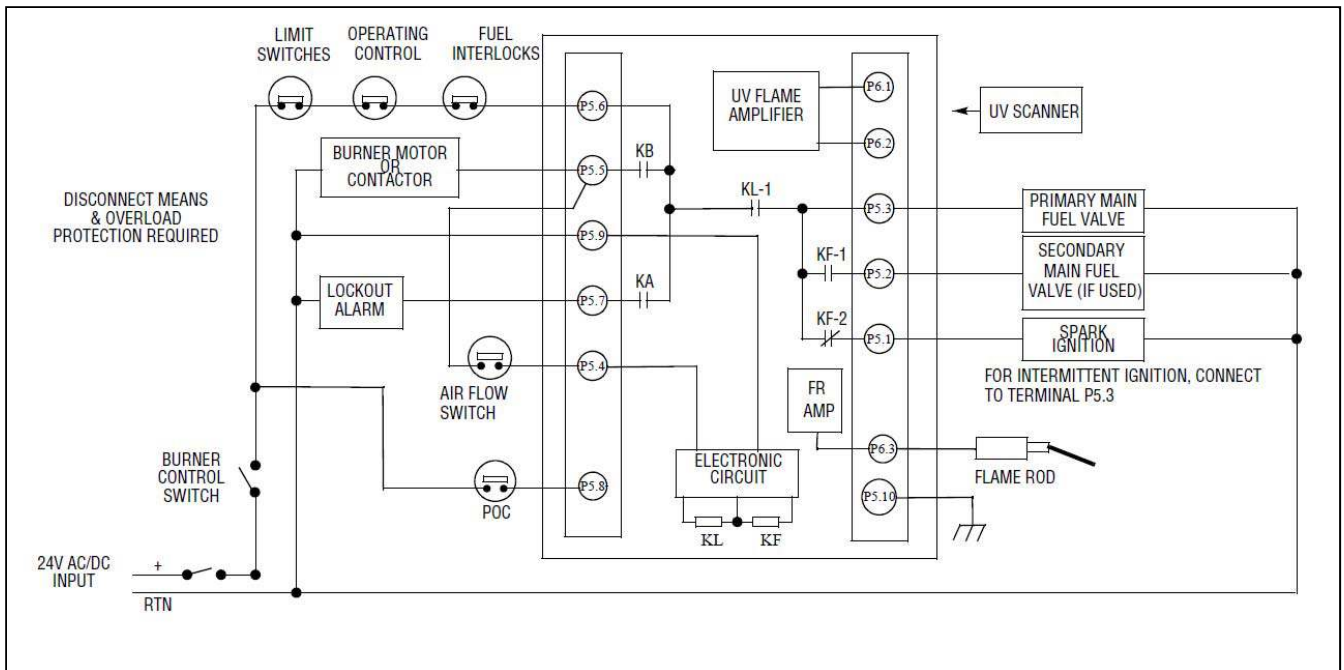


**FIGURE 1. TYPICAL WIRING ARRANGEMENT FOR PILOT IGNITED BURNER.**



Use moisture resistant wire suitable for at least 90° C.

**FIGURE 2. TYPICAL WIRING ARRANGEMENT FOR DIRECT SPARK IGNITED BURNER**



Use moisture resistant wire suitable for at least 90° C.



**CAUTION:** Control wiring procedures which deviate from those shown in the diagrams may bypass safety functions designed in the control. Contact Fireye Representative before deviating from the recommended wiring diagrams.



---

## NOTICE

When Fireeye products are combined with equipment manufactured by others and/or integrated into systems designed or manufactured by others, the Fireeye warranty, as stated in its General Terms and Conditions of Sale, pertains only to the Fireeye products and not to any other equipment or to the combined system or its overall performance.

---

## WARRANTIES

FIREYE guarantees for *one year from the date of installation or 18 months from date of manufacture* of its products to replace, or, at its option, to repair any product or part thereof (except lamps, electronic tubes and photocells) which is found defective in material or workmanship or which otherwise fails to conform to the description of the product on the face of its sales order. **THE FOREGOING IS IN LIEU OF ALL OTHER WARRANTIES AND FIREYE MAKES NO WARRANTY OF MERCHANTABILITY OR ANY OTHER WARRANTY, EXPRESS OR IMPLIED.** Except as specifically stated in these general terms and conditions of sale, remedies with respect to any product or part number manufactured or sold by Fireeye shall be limited exclusively to the right to replacement or repair as above provided. In no event shall Fireeye be liable for consequential or special damages of any nature that may arise in connection with such product or part.



**FIREYE**  
3 Manchester Road  
Derry, New Hampshire 03038  
[www.fireeye.com](http://www.fireeye.com)

**M-4001**  
November 7, 2019  
Supersedes July 16, 2019