

### SQV Series Electromotive Valve Actuators (For Use with 2-1/2-Inch to 6-Inch Pressure Independent Control Valves)



#### Features

- Operating voltage: AC/DC 24V
- Control signals: 3-position, DC 0 to 10V, DC 4 to 20 mA
- Fail-safe function
- Position feedback
- Manual adjuster
- Position and status indication (LED)
- Selectable positioning times from 40 to 240 seconds
- Selection of acting direction and flow characteristic
- Direct mounting on Pressure Independent Control Valves
- UL Listed

#### Application



Electromotoric actuators to operate Siemens Pressure Independent Control Valves with 3/4-inch (20 mm) and 1-1/2-inch (40 mm) stroke as control valves for large air handling units and distribution of hot and chilled water.

#### Product Numbers

**Table 1.**

Product Number	Control Signal	APC
SQV91P30U	Floating or 0 to 10V, Fail Open (FO)	238
SQV91P40U	Floating or 0 to 10V, Fail Closed (FC)	239

#### Warning/Caution Notations

<b>WARNING:</b>		Personal injury or loss of life may occur if you do not perform a procedure as specified.
<b>CAUTION:</b>		Equipment damage or loss of data may occur if you do not follow a procedure as specified.

<b>Specifications</b>	Operating voltage	24 Vac $\pm$ 20% 24 Vdc $\pm$ 15%
	<b>Power supply</b>	Frequency Fusing of supply lines Power consumption
		50 to 60 Hz Maximum 10 Amp slow 20 VA/7.5 W
<b>Operating data</b>	Positioning time open/close	40 seconds (default for 3/4-inch [20 mm] stroke) Positioning time depends on the DIP switch setting. See Table 1.
	Positioning force	$\geq$ 247 lb (1100 N)
	Nominal stroke	3/4-inch (20 mm) to 1-1/2-inch (40 mm)
	Admissible temperature of medium in the valve	34°F to 248°F (1°C to 120°C)
<b>Signal inputs</b>	Terminals G1, G2	3-position
	Voltage	24 Vac $\pm$ 20% 24 Vdc $\pm$ 15%
	Terminal Yu	
	Voltage	0 to 10 Vdc
	Input impedance	$\geq$ 100K $\Omega$
	Terminal Yi	
Power	DC 4 to 20 mA	
Input impedance	50 $\Omega$	
<b>Fail-safe function</b>	Terminal G	
	SQV91P30U	Loss of operating voltage Actuator stem retracted, pressure independent valve fully open (100%)
	SQV91P40U	Loss of operating voltage Actuator stem extended, pressure independent valve fully closed (0%)
Spring return time	15 sec (for 3/4-inch [20 mm] stroke) 30 sec (for 1-1/2-inch [40 mm] stroke)	
<b>Position feedback</b>	Position feedback U	DC 0 to 10V $\pm$ 1%
	Load impedance	$\geq$ 2.5K $\Omega$ resistive
	Load	Maximum 4 mA
<b>Electrical connections</b>	Wire cross-sectional areas	16 to 20 AWG
	Cable entries (1/2" conduit adapter included)	2 openings M20 x 1 1 opening M16 x 1.5
<b>Degree of protection</b>	Housing from vertical to horizontal Insulating class, AC/DC 24V	NEMA 4/4X (IP 66) III
<b>Environmental conditions</b>	Operation	
	Mounting location	Indoors (weather-protected)
	Temperature	32°F to 122°F (0°C to 50°C)
	Humidity (non-condensing)	<95% rh
	Transport	
	Temperature	-22°F to 158°F (-30°C to 70°C)
Humidity	<95% rh	
Storage		
Temperature	-22°F to 149°F (-30°C to 65°C)	
Humidity	5 to 95% rh	

**Specifications,  
 Continued**

UL Listed  
 cUL Listed

UL 873  
 Canadian Standard 22.2 No. 24.93

**Regulatory agencies**

**Dimensions**

See *Dimensions*

**Technical/  
 Mechanical Design**

The actuator can be operated as a 3-position or modulating actuator in two acting directions depending on the type of connection. It is suitable for pressure independent control valves with 20 mm or 40 mm stroke. The stroke is calibrated automatically during initialization.

The actuator includes a position feedback.

The actuator travels to the end position in the event of power loss, see *Fail-safe function*. Up to 45 seconds pass until the actuator is available again following a restart or start after the fail-safe function is triggered.

The positioning time (40 to 240 seconds) and the flow characteristic (lin/log) can be set via the DIP switches.

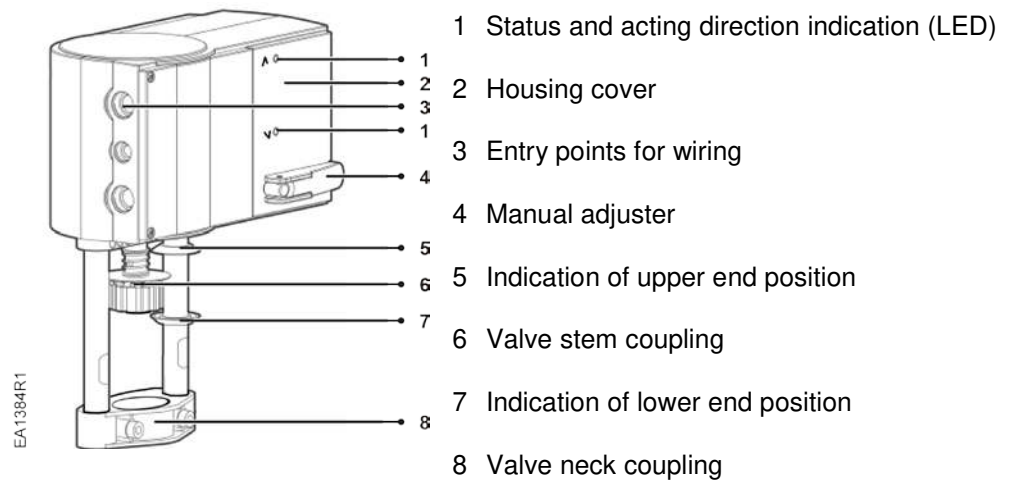

**Figure 1. Components.**

**Manual mode**

The manual adjuster allows for manually setting the position. The motor is switched off when the manual adjuster is engaged. The fail-safe function (spring return) is reactivated after the manual adjuster is disengaged, and the actuator travels again to the set position without calibration.

The actuator remains in the manual mode without active operating voltage for as long as the manual adjuster is engaged.

**Initialization, automatic coupling, calibration**

The actuator independently calibrates itself for each type of connection. Initialization occurs as soon as operating voltage is supplied for the first time and the waiting period ends. The actuator travels to the lower stop of the pressure independent control valve, thus enabling automatic coupling with the valve stem. It then travels to the upper stop, records and stores it.

Recalibration can be manually triggered any time, see *Recalibration*.

**Three-position control signal**

The pressure independent control valve can travel to any position by supplying voltage to terminal G1 or G2.

- Voltage on G2:                      Actuator stem retracts, valve opens
- Voltage on G1:                      Actuator stem extends, valve closes
- No voltage on G1 and G2:      Actuator stem stays at the applicable position

Changeover of acting direction

The acting direction of the stroke can be reversed by exchanging connections G1 and G2.

Direct acting

Positioning signal OPEN on G2.      Positioning signal CLOSED on G1.

Reverse acting

Positioning signal OPEN on G1.      Positioning signal CLOSED on G2.

Notes

- Do not use connection Yu (0 to 10 Vdc) and Yi (DC 4 to 20 mA).
- Positioning times can be selected: see *Positioning times*.
- Valve characteristic curves "lin" or "log" **cannot** be selected with 3-position control.
- Position feedback U is activated after initialization/calibration.

Electronic motor shutdown is triggered in the end positions (valve stop or upon reaching maximum stroke) or by overload (no end switch).

**Modulating control signals Yu (0 to 10 Vdc) and Yi (DC 4 to 20 mA)**

The pressure independent control valve can be driven to any position by connecting a continuous positioning signal Yu or Yi. The acting direction can be determined (direct/reverse acting) by connecting the operating voltage to G1 or G2:

Direct acting

Operating voltage AC/DC 24V on G1:

- Positioning signal to Yu, Yi increasing:      Actuator stem retracts, valve opens.
- Positioning signal to Yu, Yi decreasing:      Actuator stem extends, valve closes.
- Positioning signal to Yu, Yi continuous:      Actuator stem remains in the respective position.

Reverse acting

Operating voltage AC/DC 24V on G2:

- Positioning signal to Yu, Yi increasing:      Actuator stem extends, valve closes.
- Positioning signal to Yu, Yi decreasing:      Actuator stem retracts, valve opens.
- Positioning signal to Yu, Yi continuous:      Actuator stem remains in the respective position.

Acting Direction	Position Signal	Operating Voltage	Actuator Stem	Pressure Independent Control Valve
Direct Acting	Yu, Yi increasing	G1 to AC/DC 24V	Retracts	Opens
Reverse Acting	Yu, Yi increasing	G2 to AC/DC 24V	Extends	Closes

Notes

- The input with the higher value has priority when a positioning signal is available at both Yu and Yi.
- The actuator travels to the applicable end position depending on the selected acting direction if Yu or Yi are interrupted:  
 Operating voltage to G1      Actuator stem extends.  
 Operating voltage to G2      Actuator stem retracts.
- Positioning times can be selected, see *Positioning times*.
- Valve characteristic curves "lin" or "log" **can** be selected with modulating control.
- Position feedback U is activated after initialization/calibration.
- Up to five actuators can be controlled in parallel with one controller.

**Position feedback U**

Position feedback U (0 to 10 Vdc) is always proportional to stroke H for the actuator.

DIP Switch	Flow Characteristics	Position Feedback U
lin = linear <sup>1)</sup>		
log = equal percentage, n <sub>gl</sub> = 3 (logarithmic normal)		
log = equal percentage, n <sub>gl</sub> = 3 (exponential normal)		

EA1385R1

1) Factory setting

**Fail-safe function**

The actuator travels to the applicable end position (the stem retracts or extends depending on the model) using the preloaded spring if operating voltage to terminal G is lost or shut down. In this case, the actuator's control function is locked for 45 seconds (both LEDs are green) to reach the end position at any rate. There is no recalibration. The reset positioning speed ensures that no pressure surges occur in the piping.

End position:

SQV91P30U	Actuator stem retracted	Valve opened (V = 100%)
SQV91P40U	Actuator stem extended	Valve closed (V = 0%)

---

**Recalibration**

Recalibration can be manually triggered any time:

1. Supply operating voltage.
2. Engage and disengage the manual adjuster twice within 4 seconds.
  - Both LEDs flash green.
  - Both LEDs are steady green (indicates that recalibration was successful)
3. Normal control function resumes.

**NOTES:**

- Position feedback U is inactive or corresponds to value "0".
  - The shortest possible runtime is initialized.
  - Recalibration is valid only after the entire process is completed.
  - Additional engaging of the manual adjuster interrupts the process.
- 

**Blockage detection**

The valve actuator indicates detected blockage by setting the feedback signal to 0V after approximately 90 seconds. The actuator, however, tries to overcome the blockage during this period. Normal control function is reactivated if the blockage is overcome and position feedback U is once again available.

---

## Response at end positions

Blockage detection is always operational. In other words, the actuator demonstrates the following response at end positions  $H_{100}$  and  $H_0$  not only during initialization and calibration, but also during normal control operation:

1. The actuator travels to the end position; the LED is lit in the direction of travel.
2. It detects the end position; both LEDs are lit green.
3. It briefly travels in the opposite direction; the LED is lit in the direction of travel.
4. It returns to the end position; LED is lit in the direction of travel
5. It detects the end position; both LEDs are lit green.

This response is repeated with time intervals between travels increasing exponentially. The intervals are:















25 seconds  
1 min 40 seconds  
6 min 40 seconds  
26 min  
1 h 46 min 40 seconds  
7 h 6 min 40 seconds  
1 day 4 h 26 min 40 seconds

for the previous interval.

---

**Status and acting direction indication (LED)**

The status and acting direction consists of two green, lit LEDs.

Indication		Function
 	<ul style="list-style-type: none"> <li>▪ LED flashes green</li> <li>▪ LED flashes green</li> </ul>	<ul style="list-style-type: none"> <li>▪ Initialization</li> <li>▪ Manual mode</li> <li>▪ Delay after operating voltage is supplied, or the fail safe function is triggered</li> </ul>
 	<ul style="list-style-type: none"> <li>▪ Steady green</li> <li>▪ --</li> </ul>	Actuator stem retracts
 	<ul style="list-style-type: none"> <li>▪ --</li> <li>▪ Steady green</li> </ul>	Actuator stem extends
 	<ul style="list-style-type: none"> <li>▪ Steady green</li> <li>▪ Steady green</li> </ul>	End position is reached
 	<ul style="list-style-type: none"> <li>▪ LED flashes green</li> <li>▪ --</li> </ul>	Blockage or foreign object detected during retraction
 	<ul style="list-style-type: none"> <li>▪ --</li> <li>▪ LED flashes green</li> </ul>	Blockage or foreign object detected during extension
 	<ul style="list-style-type: none"> <li>▪ --</li> <li>▪ --</li> </ul>	No operating voltage



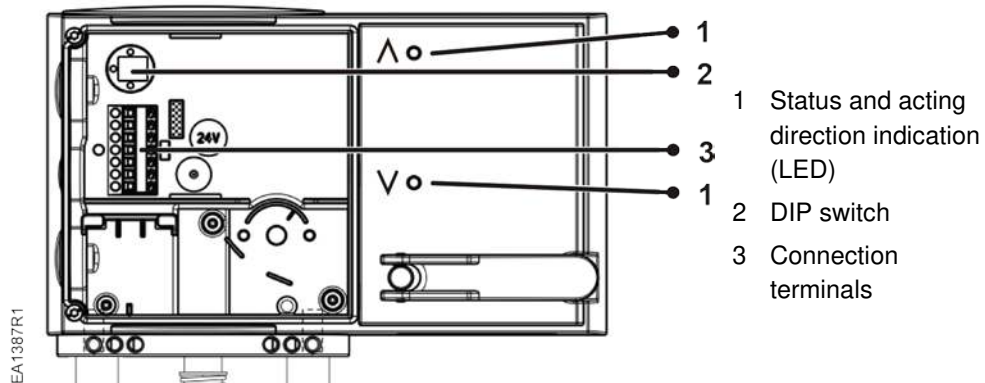

EA1386R1



**Figure 2. Actuator Components.**

**DIP Switches**

**Table 1. DIP Switch Positioning Times.**





DIP Switch	Speed	Positioning Time <sup>1)</sup>	
		20 mm	40 mm
	2 seconds/mm	40 sec <sup>2)</sup>	80 sec <sup>2)</sup>
	3 seconds/mm	60 sec	120 sec
	4,5 seconds/mm	90 sec	180 sec
	6 seconds/mm	120 sec	240 sec

EA1388R1

<sup>1)</sup> Tolerance: ± 1 second

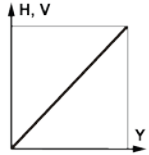
<sup>2)</sup> Factory setting

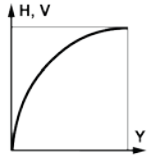
**Table 2. DIP Switch Flow Characteristics.**

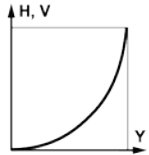
DIP Switch	Flow Characteristics	
	lin = linear <sup>1)</sup>	
 	log = equal percentage, $n_{gl} = 3$ (logarithmic normal)	
	log = equal percentage, $n_{gl} = 3$ (exponential normal)	

EA1389R1

1) Factory setting

**NOTE:** The flow characteristics can be used only for connections with constant positioning signals 0 to 10 Vdc and DC 4 to 20 mA.



**Notes**

**Engineering**

- Install electrical connections in accordance with local regulations on electric installations as well as internal or connecting diagrams. See *Connection Diagrams*.
- Observe safety regulations and restrictions designed to ensure the safety of people and property at all times.
- An internal controller controls the actuator for 3-position or DC 4 to 20 mA positioning signal connection types. See *Connection Diagrams*.
- For 0 to 10 Vdc connections (input impedance  $R_i = 100\text{ k}\Omega$ ), up to 5 actuators can be controlled in parallel by a controller with a rating of 1 mA.
- Do not insulate the actuator console and valve stem, as air circulation must be ensured.
- For admissible temperatures, see *Specifications*.



**CAUTION:**

Non-observance of the above may result in accidents and fires.



**WARNING:**

Do not touch hot parts without taking proper protective measures to avoid burns.

**Installation Notes**

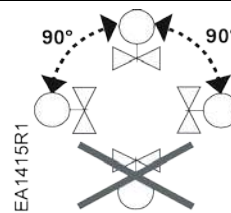

**Figure 3. Acceptable Mounting Positions.**



**CAUTION:**

Be sure to use the anti-rotation device supplied with the actuator to prevent valve maximum gpm from being accidentally changed if the actuator is rotated on the valve.

**Commissioning Notes**

- Check the wiring and carry out a functional check as part of commissioning.
- Make or check the settings as per the plant diagram for auxiliary switches and potentiometers.

**Maintenance Notes**

These actuators are maintenance-free. Regularly check actuators with safety functions.

When servicing the actuator:

1. Switch off pump and power supply.
2. Close the main shutoff valve in the pipework.
3. Release pressure in the pipes and allow them to cool down completely.
4. If necessary, disconnect electrical connections from the terminals.
5. The actuator must be correctly fitted to the valve before recommissioning.
6. Trigger stroke calibration after servicing.

**Repair**

The actuator cannot be repaired. It has to be replaced as a complete unit.



**WARNING:**

Do not remove the actuator spring due to the high risk of injury.

**Wiring Diagrams**

**0 to 10 Vdc, DC 4 to 20 mA**

**3-Position**

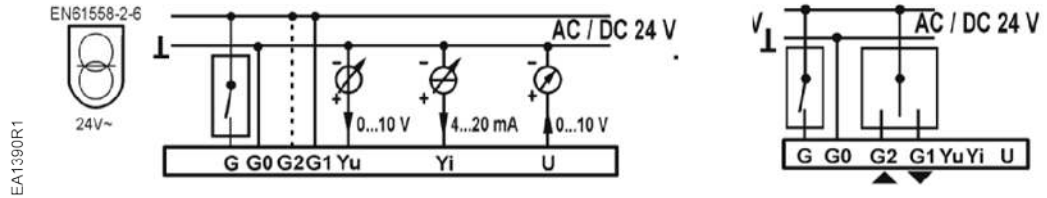

**Connection terminals**

0 to 10 Vdc  
 DC 4 to 20 mA

24 Vac/Vdc	G	System Potential
	G0	System Neutral
	G1	Y = 0 Vdc/4 mA: Actuator fully extended (increasing control signal retracts actuator stem)
	G2	Y = 0 Vdc/4 mA: Actuator fully retracted, (increasing control signal extends actuator stem)
	Yu/Yi	Control Signal 0 to 10V/4 to 20 mA
	U	Position Indication

**3-position**

24 Vac/Vdc	G	System Potential
	G0	System Neutral
	G1	Control signal: Actuator stem extends
	G2	Control signal: Actuator stem retracts

**Dimensions**

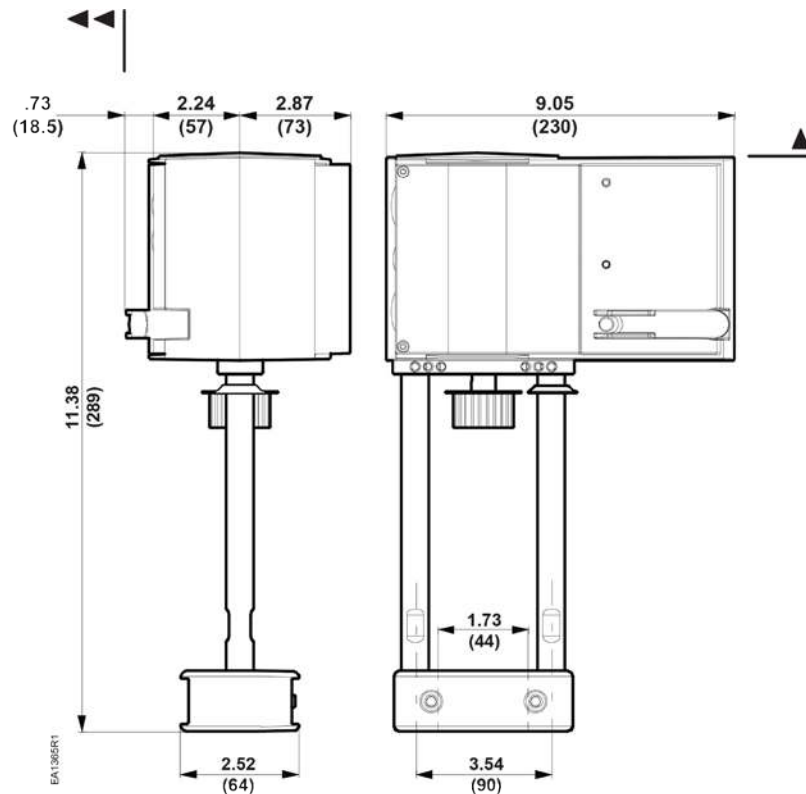

- \* Height of actuator after fitting on valve
- ◀ > 4 inches (100 mm) Minimum clearance from wall or ceiling
- ▲ > 8 inches (200 mm) for mounting, connection, operation, service, and so on

**Figure 4. Dimension in Inches (Millimeters).**

Information in this publication is based on current specifications. The company reserves the right to make changes in specifications and models as design improvements are introduced. Product or company names mentioned herein may be trademarks of their respective owners.  
 © 2015 Siemens Industry, Inc.