

OpenAir®

GNP/GAP Fail-Safe/Fail-in-Place 53 lb-in (6 Nm), Rotary, Electronic Damper Actuators



Description The OpenAir direct-coupled fail-safe/fail-in-place electronic actuators are designed for modulating, two-position, and floating control of laboratory fume hoods, constant or variable volume installations for the control of supply and exhaust and terminal units.

- Features**
- Fast operation, 2-second runtime
 - One model performs all control signals:
 - 2-position
 - Floating
 - Accepts Siemens FHC/LRC pulsed control signal
 - Modulating [0(2) to 10 Vdc and 4(0) to 20 mA]
 - Feedback standard on all models
 - Highly accurate positioning
 - Brushless DC motor technology with stall protection
 - Models available with dual, independently adjustable auxiliary switches
 - Unique self-centering shaft coupling
 - 53 lb-in (6 Nm) torque
 - UL and cUL listed, CE certified
 - 24 Vac/dc compatible
 - Manual override capability

Application Used in laboratory fume hoods, constant or variable air volume installations for the control of supply and exhaust air terminals; 53 lb-in (6 Nm) torque.



Models designed for applications that require the damper to return to a fail-safe position when there is a power failure; or models for fail-in-place.

Product Numbers

Table 1. Product Numbers.

Types	Operating Voltage	Dual Adjustable Auxiliary Switches	Action		Torque
			Fail-safe	Fail-in-Place	
GNP191.1P	24 Vac/dc	–	•	–	53 lb-in (6 Nm)
GNP196.1P		•	•	–	
GAP191.1P		–	–	•	
GAP196.1P		•	–	•	

Warning/Caution Notations

WARNING:		Personal injury or loss of life may occur if you do not perform a procedure as specified.
CAUTION:		Equipment damage may occur if you do not perform a procedure as specified.

Specifications Power Supply 24 Vac/24 Vdc	Operating voltage	24 Vac/dc $\pm 20\%$
	Frequency	50/60 Hz
	Power consumption	
	running	28 VA/19W
	holding	8 VA/5W
	Equipment rating	Class 2, in accordance with UL/CSA Class III per EN 60730
Control Signal Y/Y1	Modulating input signal (wires 8-2)	
	voltage input signal	0 to 10 Vdc (max. 35 Vdc)
	voltage input signal	2 to 10 Vdc (max. 35 Vdc)
	input resistance	< 20k ohms
	repositioning resolution	0.4%
	Floating input signal (wires 8-2)	0 or 24 Vac/dc Clockwise
Control Signal Y2	Floating input signal (wires 7-2)	0 to 24 Vac/dc Counterclockwise
Feedback Signal	Position output signal (wires 9-2)	0 to 10 Vdc
	maximum output current	DC ± 1 mA
Auxiliary Switches GNP196.1P GAP196.1P	Contact loading	6A resistive, 2A inductive
	Voltage (no mixed operation 24 Vac/230 Vac)	24 to 250 Vac
	Switching range for auxiliary switches	5° to 90°
	Step increments	5°
Function	Running torque	53 lb-in (6 Nm)
	Maximum torque	142 lb-in (16 Nm)
	Runtime for 90°	
	operating with motor	< 2 seconds
	fail-safe (on power loss)	2 seconds
	(for GNP19x only)	
Fail-Safe Operation GNP Actuator Series		On initial power-up, and after a power-fail event, the GNP actuators require up to 90 seconds for the capacitors to fully charge. During this time the actuator will respond to positioning commands but will not power-fail until the capacitors are fully charged.
Mounting	Nominal angle of rotation	90°
	Maximum angular rotation	95°
	Shaft size	1/4- to 3/4-inch (6.4 to 20.5 mm) dia. 1/4- to 1/2-inch (6.4 to 13 mm) square
	Minimum shaft length	3/4-inch (20 mm)

Housing	Enclosure	NEMA 1 IP54 according to EN 60 529 (limited positions; see <i>OpenAir® GNP/GAP Series Installation Instructions</i> [129-541])
	Material	Die-cast aluminum alloy
	Gear lubrication	Silicone-free
Ambient Conditions	Ambient temperature operation	-0°F to 122°F (-18°C to 50°C)
	storage/transport	-26°F to 158°F (-32°C to 70°C)
	Ambient humidity (non-condensing)	95% rh
Agency Certification	UL listed	UL 873
	cUL listed	C22, 2 No. 24-93
CE Conformity	Electromagnetic compatibility (EMC)	2004/108/EC
	NOTE: These devices were approved for installation in plenum areas by Underwriters Laboratories, Inc. (UL) per UL 1995.	
Miscellaneous	Cable length	3 feet (0.9 m) length
	Life cycle	Designed for over 100,000 full stroke cycles and a minimum of seven million repositions at rated torque and temperature
	Dimensions	8-3/8-in. H × 3-1/4-in. W × 2-3/8-in. D (212 mm H × 83 mm W × 60 mm D)
	Shipping weight	3 lbs 6 oz

Service Parts

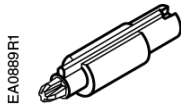

**985-098
Adjustment Tool.**

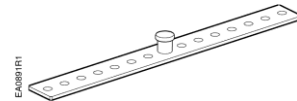

**985-092
Anti-Rotation (Mounting) Bracket.**

Figure 1. Series Service Parts.

Operation

2-position control

Two-position control requires three wires. Apply 24 Vac/dc power to wire 1 (red) and wire 2 (black). Applying a 24 Vac/dc control signal to wire 7 (orange) causes the actuator to rotate counterclockwise. When the operating voltage is removed from wire 7 (orange), the actuator rotates clockwise.

Floating control

The actuator's angle of rotation is proportional to the length of time the signal is applied. A 24 Vac/dc control signal to wire 8 (gray) causes the actuator to rotate clockwise. A 24 Vac/dc control signal to wire 7 (orange) causes the actuator to rotate counterclockwise. With no control signal applied, the actuator holds its position.

Modulating control

Apply a continuous 0(2) to 10 Vdc or 0(4) to 20 mA control signal between wire 8 (gray) and wire 2 (black) to operate the damper actuator. The angle of rotation is proportional to the control signal.

A 0 to 10 Vdc modulating output signal is available between wire 9 (pink) and wire 2 (black) to monitor the position of the actuator.

Fail-safe

In the event of a power failure, the GNP fail-safe actuator returns to the fail-safe position (see Figure 5.)

NOTE: The operation described above is valid for the factory default setting for rotation direction (see Figure 5 and Figure 6).

Life expectancy

An improperly tuned loop will cause excessive repositioning that will shorten the life of the actuator.

Mechanical Range Adjustment

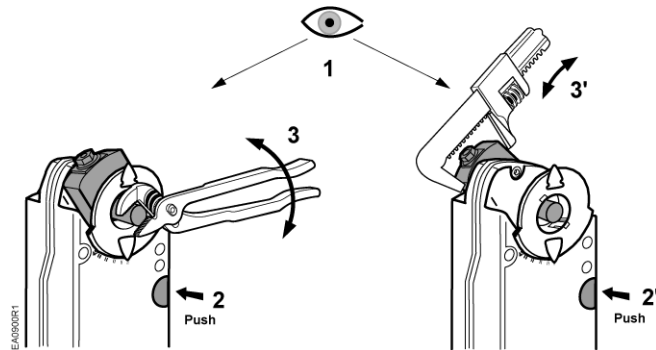
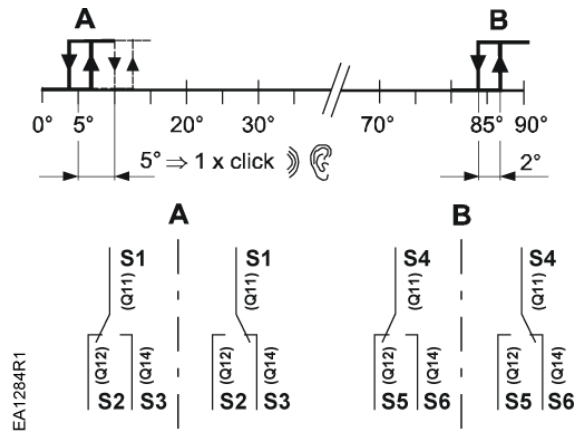

Figure 2. Mechanical Range Adjustment.

Dual Auxiliary Switch



Actuator rotary range with the shaft adapter mounted at position 0.

Setting range for Switches A and B
 Setting step: 5°
 Switching hysteresis: 2°

Figure 3.

To change the settings of A and B:

1. Make sure the actuator is in the 0, fail-safe position. The scale is valid only in the 0 position.
2. Use the adjustment tool provided with the actuator to turn the switch adjustment dials to the desired setting at which a signal is to be given.

Factory setting:
 Switch A = 5°
 Switch B = 85°

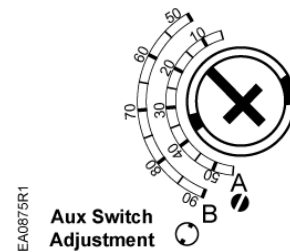

Figure 4.

NOTE: Use the long arm of the "T" to point to the position of Switch A. Use the narrower tab on the red ring to point to the position of Switch B.

Actuator Operation Settings

- The black position indicates the active switch setting.
- For Siemens FHC/LRC pulsed control signal applications, see Figure 7.
- On initial power-up, and after a power-fail event, the GNP actuators require up to 90 seconds to fully charge their capacitors. During this time the actuator will respond to positioning commands, but will not power-fail until the capacitors are fully charged.

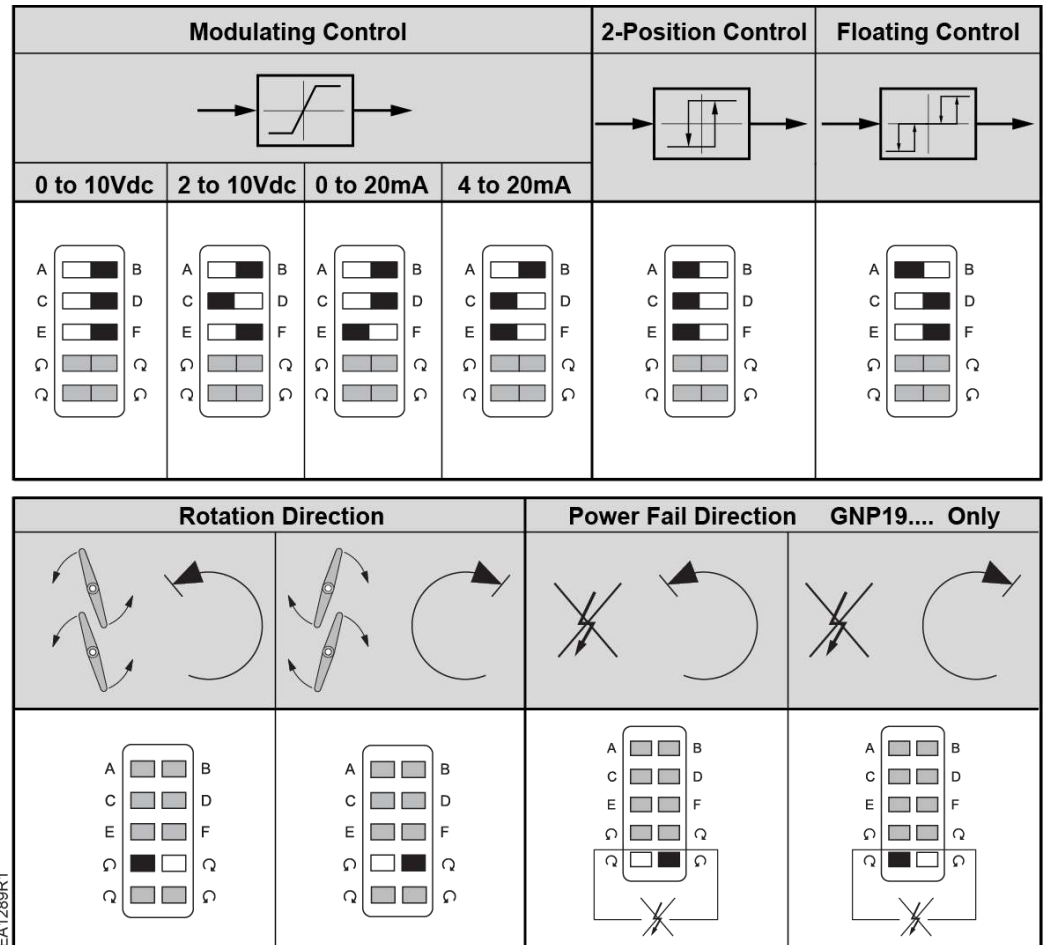

Figure 5. Setting.

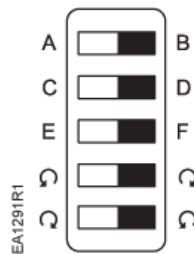

Figure 6. Siemens Factory Default Setting.

**Siemens FHC/LRC
 Pulsed Control Signal**

	EA1294R1		EA1295R1	
Actuator Action	Wire 7 (Orange)	Wire 8 (Gray)	Wire 7 (Orange)	Wire 8 (Gray)
Rotate clockwise	24V	24V	—	—
Rotate counterclockwise	—	—	24V	24V
Hold position	24V	—	24V	—
Hold position	—	24V	—	24V

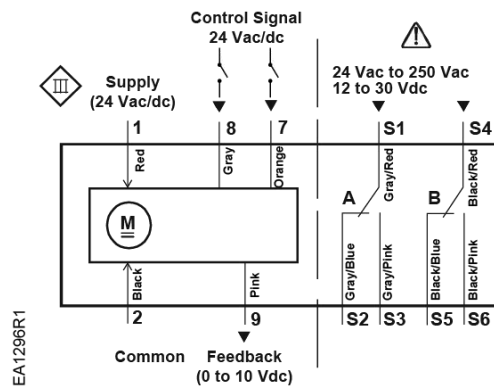

Figure 7. Pulsed Control Signal.



CAUTION:

Unused wires must be properly terminated.

Wiring

All wiring must conform to NEC and local codes and regulations.

Use earth ground isolating step-down Class 2 transformers. Do not use autotransformers.

The maximum rating for a Class 2 step-down transformer is 100 VA. Determine the supply transformer rating by summing the VA ratings of all actuators and all other components used. It is recommended that one transformer power no more than 10 actuators (or 80% of its VA).



WARNING:

Mixed switch operation is not permitted to the switching outputs of both auxiliary switches (A and B).

Either AC line voltage from the same phase must be applied to all six outputs of the dual auxiliary switches, or UL-Class 2 voltage (SELV for CE conformance) must be applied to all six outputs.

NOTE: With plenum cables only UL-Class 2 voltage (SELV for CE conformance) is permitted.

Wiring, Continued



WARNING:

Installations requiring **CE** Conformance:

- Except for the auxiliary switches (See *Warning* above) all wiring for 24 Vac/dc actuators must only be safety extra-low voltage (SELV) or protective extra-low voltage (PELV) per HD384.
- Use safety transformers per EN61558 with double isolation, designed for 100% duty-cycle for supplying SELV or PELV circuits.
- Over-current protection for supply lines is maximum 10A.

Wire Designations

Each wire has the standard symbol printed on it. See Table 2.

Table 2. Wire Designations.

Connecting	Standard Symbol	Function	Color	Color Symbol
24 Vac/dc Actuator	1	Supply	Red	RD
	2	Common	Black	BK
	7	2-position control signal Floating (CCW) Control signal	Orange	OG
	8	Modulating: 0 (2) to 10 Vdc/0 (4) to 20 mA Floating: (CW) Control signal	Gray	GY
	9	Feedback: 0 to 10 Vdc	Pink	PK
Auxiliary Switches	S1	Switch A Common	Gray/red	GYRD
	S2	Switch A N.C.	Gray/blue	GYBU
	S3	Switch A N.O.	Gray/pink	GYPK
	S4	Switch B Common	Black/red	BKRD
	S5	Switch B N.C.	Black/blue	BKBU
	S6	Switch B N.O.	Black/pink	BKPK

Wiring Diagrams



CAUTION:

Unused wires must be properly terminated.

2-Position Control

NOTE: Two-position control requires three wires.

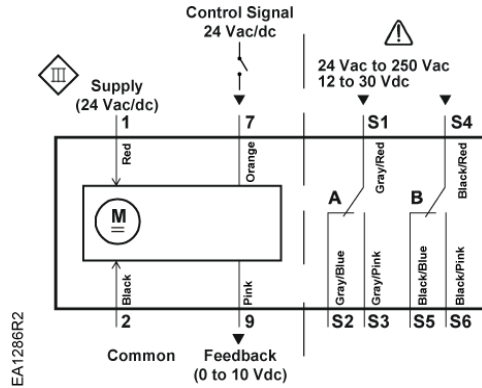

Figure 8. Two- Position Wiring Diagram.

Floating Control

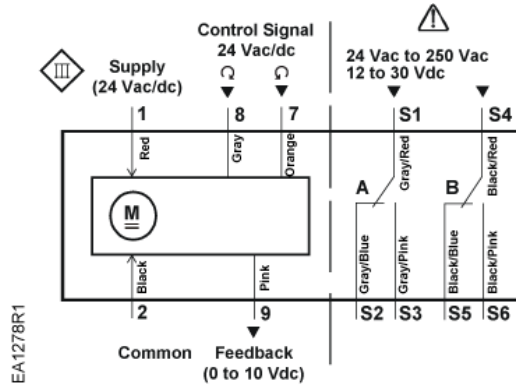

Figure 9. Floating Control Wiring Diagram.

Modulating Control

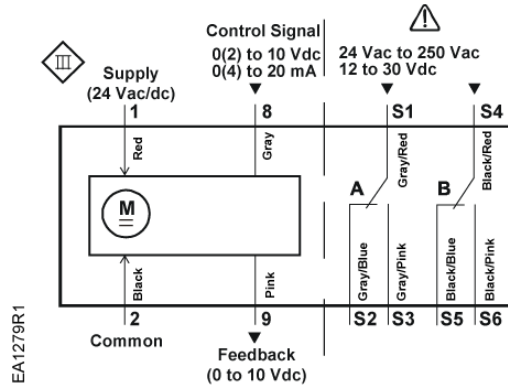

Figure 10. Modulating Control Wiring Diagram.

Service



WARNING:

Do not open the actuator.
 If the actuator is inoperative, replace the unit.

Troubleshooting



WARNING:

To avoid injury or loss of life, pay attention to any hazardous voltage (For example, 120 Vac) when performing checks.

- Check that the wires are connected correctly.
- Check that DIP switches are set correctly, if used.
- Use a Digital Multimeter (DMM) to verify that the operating voltage is within range.

If the actuator is not working, check the damper for blockage. If blocked, remove the obstacle and cycle the actuator power off and on. The actuator should resume normal operating mode.

Dimensions

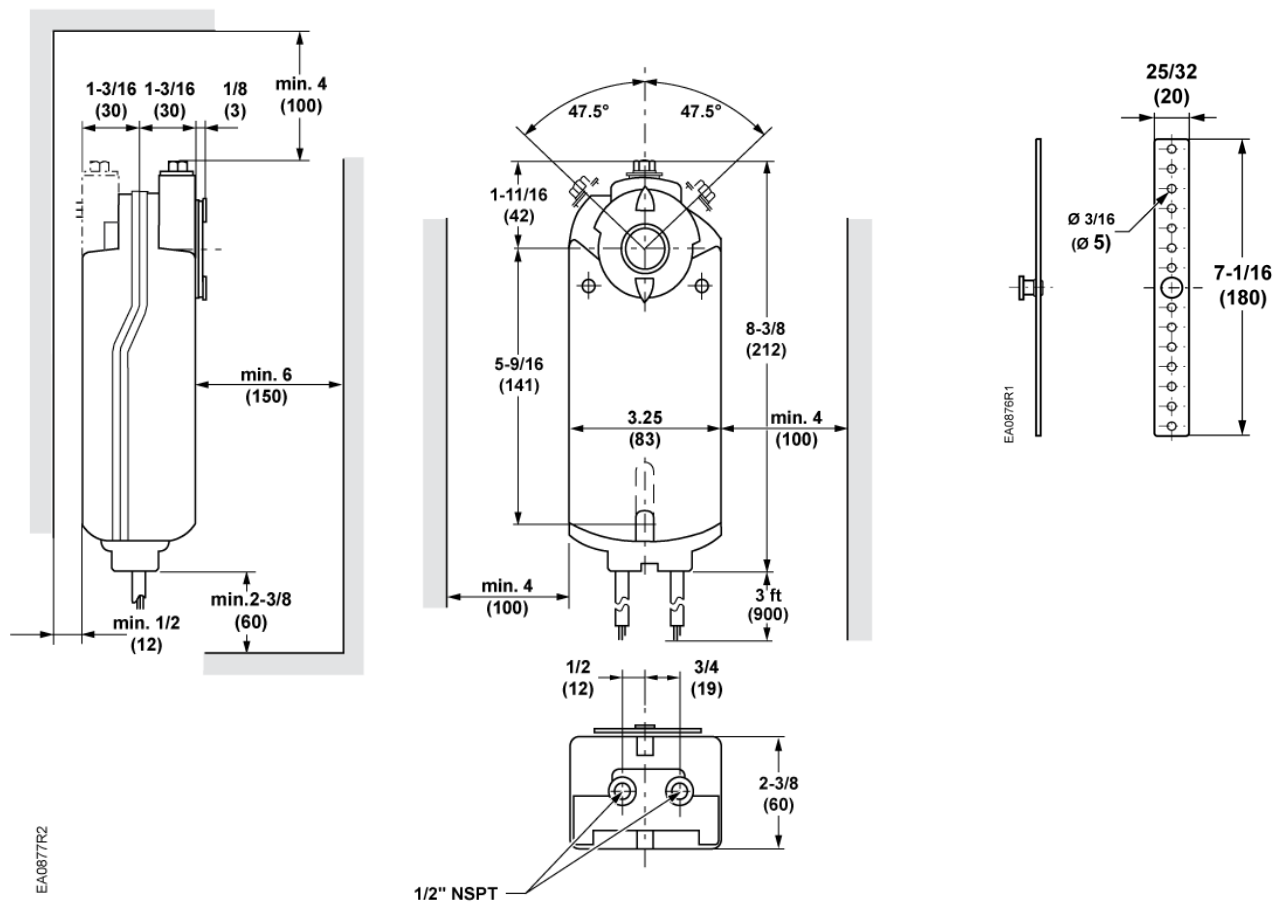

Figure 11. GNP/GAP Dimensions in Inches (Millimeters).

Information in this publication is based on current specifications. The company reserves the right to make changes in specifications and models as design improvements are introduced. OpenAir is a registered trademark of Siemens Schweiz AG. Other product or company names mentioned herein may be the trademarks of their respective owners. © 2021 Siemens Industry, Inc.