

## OpenAir® GBB/GIB Series Electronic Damper Actuators

### Non-spring Return 24 Vac, Floating Control, Rotary



**Description**                      The OpenAir direct coupled 24 Vac, non-spring return (NSR) rotary electric actuator is designed for floating control of building HVAC dampers.

- Features**
- Unique self-centering shaft coupling
  - All metal housing
  - Manual override
  - Independently adjustable dual auxiliary switches available
  - Built in potentiometer option
  - Two torque ranges available
  - UL, CE and cUL listed



**Application**                      These actuators are used in constant or variable air volume installations for the control of return air, mixed air, exhaust, and face and bypass dampers requiring up to 221 lb-in (25 Nm) or 310 lb-in (35 Nm) torque.

**Product Numbers**

**Table 1.**

<b>24 Vac Operating Voltage</b>				
<b>Torque</b>	<b>Cabling</b>	<b>Standard</b>	<b>Potentiometer Only</b>	<b>Auxiliary Switches Only</b>
221 lb-in (25 Nm)	Standard	GBB131.1U	GBB132.1U	GBB136.1U
	Plenum	GBB131.1P	GBB132.1P	GBB136.1P
310 lb-in (35 Nm)	Standard	GIB131.1U	GIB132.1U	GIB136.1U
	Plenum	GIB131.1P	—	GIB136.1P

## Warning/Caution Notations

<b>WARNING:</b>		Personal injury/loss of life may occur if you do not perform a procedure as specified.
<b>CAUTION:</b>		Equipment damage or loss of data may occur if you do not perform a procedure as specified.

<b>Specifications</b>	Operating voltage	24 Vac, ±20%
	Frequency	50/60 Hz
<b>Power supply</b>	Power consumption:	7 VA/7W
<b>Equipment rating</b>	Operating voltage	Class 2, in accordance with UL/CSA
	Plenum type actuators as whole device	Class 2, in accordance with UL/CSA
<b>Auxiliary features</b>	<b>Feedback potentiometer (GBB132x)</b>	
	Sliding contact (P2)	0 to 1000 ohm
	Load	<1W
	Voltage	<24 Vac/dc
	<b>Control signal adjustment</b>	
	Offset (start point)	Between 0 to 5 Vdc
	Factory setting	0 Vdc
	Span	Between 2 to 30 Vdc
	<b>Dual auxiliary switches</b>	
	AC rating (standard cable)	24 to 250 Vac AC 6A resistive AC 2A general purpose
	AC rating (Plenum cable)	24 Vac AC 4A resistive AC 2A general purpose
	DC rating (Standard/Plenum cable)	12 to 30 Vdc DC 2A
	Switch Range	
	<b>Switch A</b>	0 to 90° with 5° intervals
Recommended range usage	0 to 45°	
Factory setting	5°	
<b>Switch B</b>	0 to 90° with 5° intervals	
Recommended range usage	45 to 90°	
Factory setting	85°	
Switching hysteresis	2°	



**WARNING:**

Apply only line voltage or only Class 2 voltage to the switching outputs of both auxiliary switches A and B. Mixed operation is not permissible. See *Wiring* for details.



**CAUTION:**

It is recommended to switch off the power during two-position control when the actuator has reached the open or closed position to enhance life span and reduce power consumption.

<b>Specifications, Continued</b>	Running torque		
	GBB...	221 lb-in (25 Nm)	
	GIB...	310 lb-in (35 Nm)	
	<b>Function</b>	Runtime for 90° opening or closing	150 seconds at 50 Hz 125 seconds at 60 Hz
		Nominal angle of rotation	90°
	Maximum angular rotation	95°	
<b>Mounting</b>	Shaft size	3/8 to 1-inch (8 to 25.6 mm) diameter 1/4 to 5/8-inch (6 to 18 mm) square	
	Minimum shaft length	3/4-inch (20 mm)	
<b>Housing</b>	Enclosure	NEMA 2 in vertical position to 90° to the left and right of vertical See Figure 14. NEMA 3R rated when installed with ASK75.1U Weather Shield in the vertical position. See <i>Accessories</i> . IP54 according to EN 60 529	
	Material	Die-cast aluminum alloy	
	Gear lubrication	Silicone-free	
	<b>Ambient conditions</b>	Ambient temperature	
	operation	-25°F to 130°F (-32°C to 55°C)	
	storage and transport	-40°F to 158°F (-40°C to 70°C)	
	Ambient humidity (non-condensing)	95% rh	
<b>Agency certification</b>		UL listed to UL873 cUL certified to Canadian Standard C22.2 No. 24-93 CE conformity: Electromagnetic compatibility 2004/108/EC Low-voltage directive 2006/95/EC	
<b>Miscellaneous</b>	Pre-cabled connection	18 AWG	
	Cable length	3 feet (0.9 m) length	
	Life cycle	Designed for over 60,000 full strokes and a minimum of 1.5 million repositions at rated torque and temperature	
	Noise level	<45 dBA (running)	
	Dimensions	See Figure 26.	
	Weight	4.4 lbs (2 kg)	

## Accessories

**NOTE:** Neither the auxiliary switches nor the feedback potentiometer can be added in the field. Order the product number that includes these options.

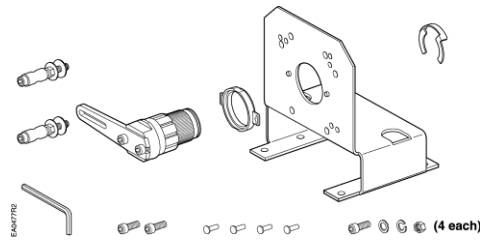

**Figure 1. Floor Mount Kit.**

**ASK71.1U:** Allows foot mounting of the OpenAir actuators. Kit should be used for in-the-air stream applications or anywhere a foot-mounted actuator can be mounted. Kit contains:

- Crank arm for changing angular rotation into a linear stroke
- Support bearing ring to minimize side loading on the actuator's output bearing
- Mounting bracket
- Required mounting fasteners

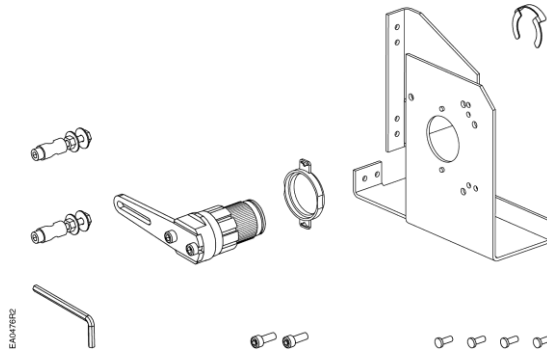

**Figure 2. Frame Mount Kit.**

**ASK71.2U:** Allows mounting of OpenAir actuators directly to a damper frame. Kit should be used with louvers and vents and in applications where use of the floor mount kit is not possible. Kit contains:

- Crank arm to change the angular rotation into a linear stroke
- Support bearing ring to minimize side loading on the actuator's output bearing
- Mounting bracket
- Required mounting fasteners

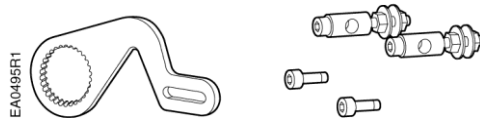

**Figure 3. Crank Arm Kit.**

**ASK71.3:** Allows a direct-coupled actuator to provide an auxiliary linear drive. Kit can be used to simultaneously drive a set of opposing or adjacent dampers with a single actuator. Kit contains:

- Crank arm to attach to the splined hub of the shaft adapter
- Required mounting fasteners

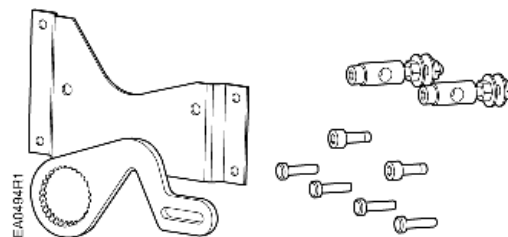
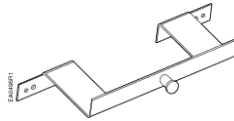

**Figure 4. Crank Arm Kit with Mounting Bracket.**

**ASK71.4:** Allows economical mounting of an OpenAir actuator to a variety of surfaces. Kit should be used in applications where the actuator can be rigidly surface mounted and a linear stroke output is required. Kit contains:

- Crank arm to attach to the splined hub of the shaft adapter
- Mounting bracket
- Required mounting fasteners

**Accessories,  
 continued**



**Figure 5. Tandem Mount Bracket.**

**ASK73.1:** Bracket provides an extended anti-rotation pin that allows two GIB13x OpenAir actuators to directly drive a single damper shaft. For use with three-position actuators.

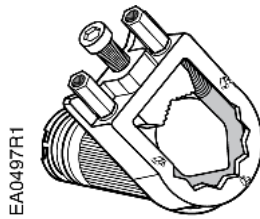
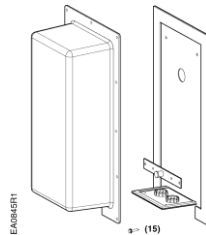

**Figure 6. Special Shaft Adapter.**

**ASK74.1U:** Shaft adapter attaches to a 1.05-inch (26.6 mm) diameter shaft; whereas, the standard self-centering adapter accepts up to a 1.00-inch (25.4 mm) diameter shaft.

Adapter can be used for coupling to 1-inch (25 mm) jackshafts that are slightly oversized. Adapter is 13/16-inches (20 mm) shorter than the height of the self-centering shaft adapter.

**985-052P20:** (no picture) Small shaft insert (package of 20) when using the GIB actuator on a damper shaft less than 3/4-inch (20 mm) diameter.



**Figure 7. NEMA 3R Weather Shield.**

**ASK75.1U:** GBB/GIB actuators are UL listed to meet NEMA 3R requirements (a degree of protection against rain, sleet, snow, and damage from external ice formation) when installed with the ASK75.1U Weather Shield and outdoor-rated conduit fittings in the vertical position. For dimensions, see Figure 24.

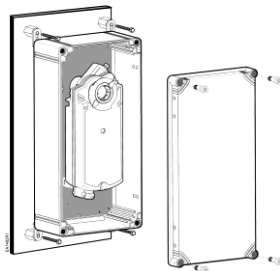

**Figure 8. NEMA Type 4X Weather Shield.**

**ASK75.7U:** GBB and GIB Actuators are UL listed to meet NEMA Type 4X requirements (a degree of protection against falling dirt, rain, sleet, snow, windblown dust, splashing water, hose-directed water, corrosion, and damage from external ice formation) when installed with an ASK75.7U Weather Shield and outdoor-rated conduit fittings. This weather shield may be mounted in any orientation. For dimensions, see Figure 25.

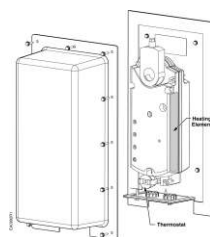

**Figure 9. Heater/Weather Shield Assembly.**

**985-106:** Provides protection for GIB, GBB and GCA OpenAir actuators in an outside low temperature. Assembly includes:

- Weather Shield (ASK75.1U)
- Heater Kit (985-105)



**985-008:** 1/2-inch (12 mm) for 1/2-inch NPT connector.

**Figure 10. Conduit Adapter.**

**Service Parts**

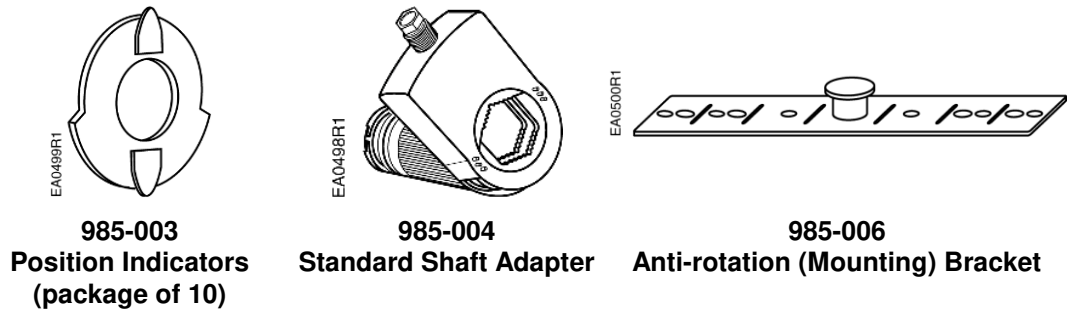

**Figure 11. Orderable Parts.**

**Actuator Components**

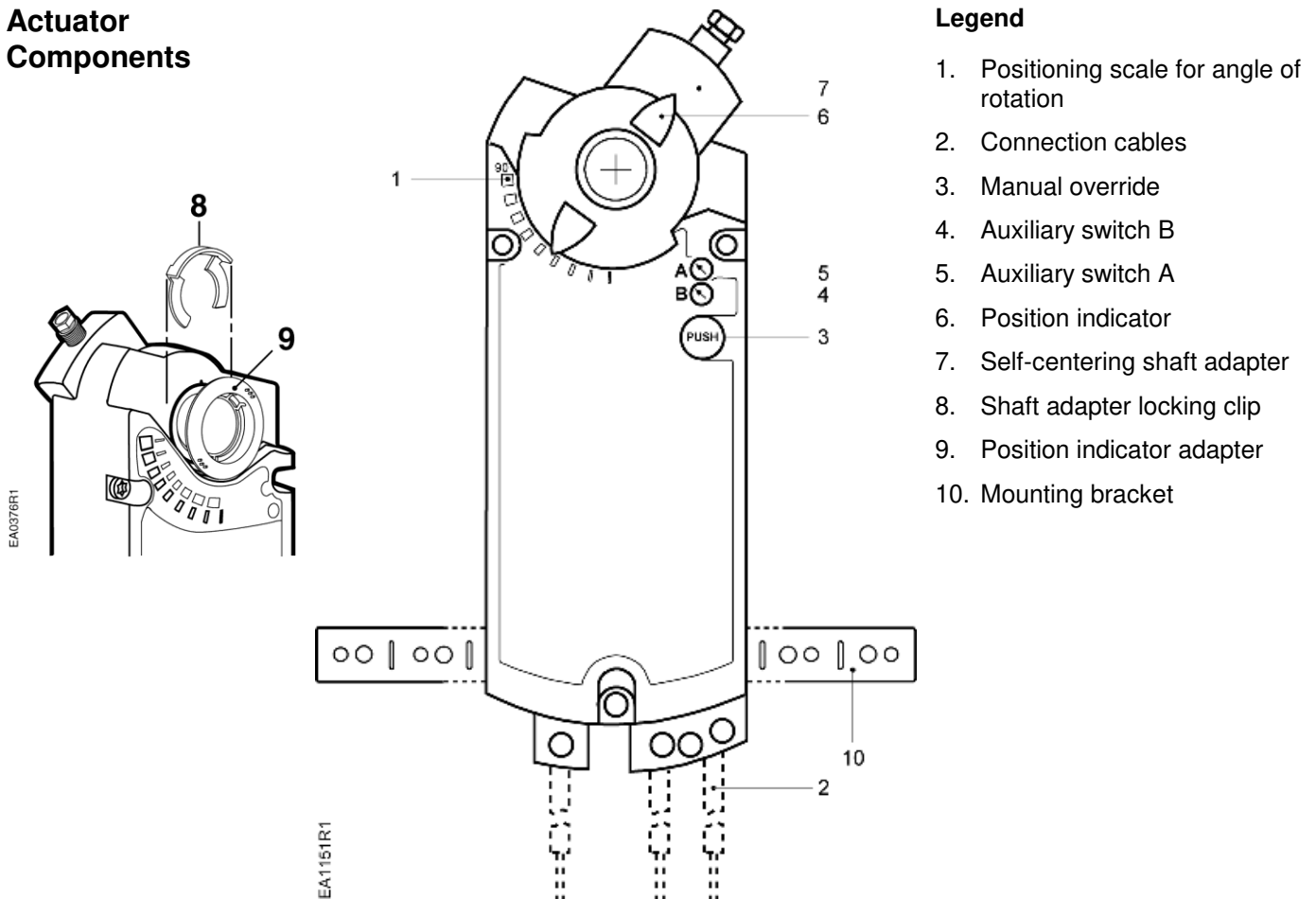

**Figure 12. Components of the Floating Control Actuator.**

**Operation**

**GBB/GIB13x**

A floating control signal controls the damper actuator. The actuator's angle of rotation is proportional to the length of time the signal is applied. A 24 Vac control signal to wires 1 and 6 (G-Y1) causes the actuator coupling to rotate clockwise. A 24 Vac control signal to wires 1 and 7 (G-Y2) causes the actuator coupling to rotate counterclockwise.

If you want to reverse the direction of rotation, wires 6 and 7 (Y1 and Y2) may be interchanged. Reverse the position indicator so that the counterclockwise 0 to 90 scale is visible. See Figure 17.

In the event of a power failure or with no control voltage, the damper actuator holds its position.

In the event of a blockage in the damper, the actuator is overload protected over the full range to prevent damage to the actuator.

**Life expectancy**

An improperly tuned loop will cause excessive repositioning that will shorten the life of the actuator.

**Dual auxiliary switch**

**GBB/GIB136**

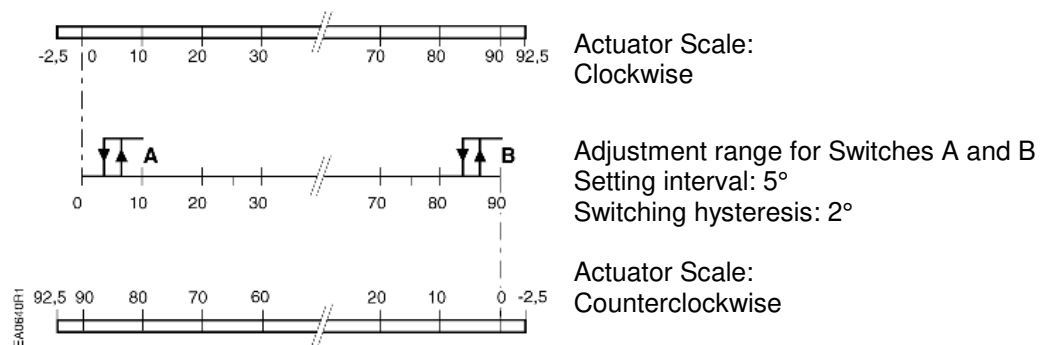

**NOTE:** The auxiliary switch setting shafts turn together with the actuator. The scales are valid only when the actuator is in the 0 position on clockwise motion.

To change the settings of A and B, use a flat-blade screwdriver to turn the switch adjustment dials to the desired setting at which a signal is to be given.

Factory setting

- Switch A 5°
- Switch B 85°

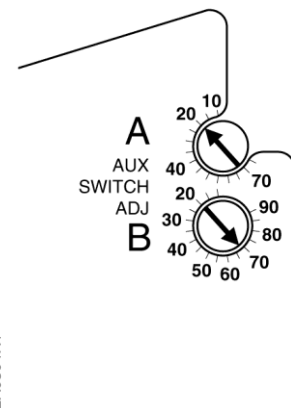

**Figure 13. Dual Auxiliary Switch Dials.**

## Sizing

The number of actuators required depends on several factors. To determine the quantity of actuators required for the installation:

1. Obtain damper torque ratings (ft-lb/ft<sup>2</sup> or Nm/m<sup>2</sup>) from the damper manufacturer.
2. Determine the area of the damper.
3. Calculate the total torque required to move the damper:

$$\text{Total Torque} = \text{Torque Rating} \times \text{Damper Area}$$

4. Select the total quantity of actuators required:

$$\text{Number of actuators} = \frac{\text{Total Damper Torque required}}{\text{SF}^1 \times \text{Actuator Torque (Refer to Specifications)}}$$

<sup>1</sup> Safety Factor: When calculating the number of actuators required, a safety factor should be included for unaccountable variables such as slight misalignments, aging of the damper, etc. A suggested safety factor is 0.80 (or 80% of the rated torque).

Mechanical coupling of the actuator is allowed if:

1. The same type of actuator is used.
2. The power trunk can handle added components.
3. The same power and control inputs go to both actuators (parallel wiring).

## Mounting and Installation

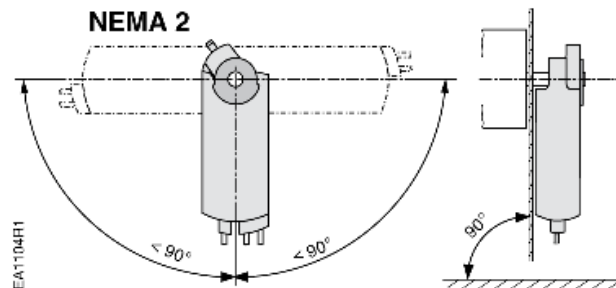

**Figure 14. Acceptable NEMA 2 positions.**

- The actuator must be placed on the damper shaft so that the front of the actuator is accessible. The label and the manual override button are the front side.
- The minimum damper drive shaft length is 3/4-inch (20 mm). The shaft length determines whether the shaft adapter will be mounted on the front or back side of the actuator.
- See *Specifications* for minimum and maximum damper shaft dimensions.
- Mount the position indicator to show either the clockwise or counterclockwise 0 to 90 scale.
- A mounting bracket is included with the actuator.
  - Detailed mounting instructions are included with each actuator.
  - The shaft adapter and mounting parts are shipped in a separate container with the actuator.
- The actuator is shipped from the factory with a 5° pre-load to ensure tight close off of the damper.



**Manual override**

To move the damper blades and lock the position with no power present:

1. Determine damper rotation: clockwise or counterclockwise.
2. Hold down the **PUSH** button.
3. Make adjustments to the damper position.
4. Release the **PUSH** button.

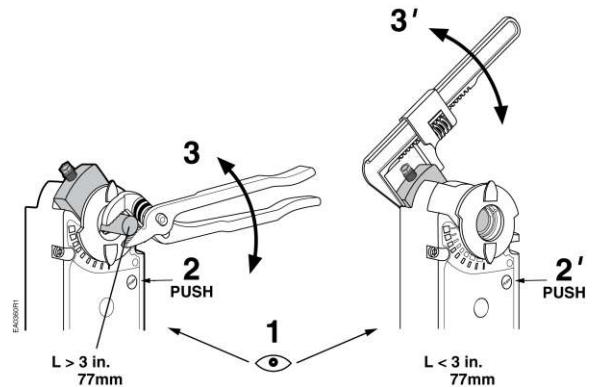

**Figure 15. Manual Override.**

Once power is restored, the actuator returns to automated control.

**Mechanical range adjustment**

The angular rotation is adjustable between 0 and 90° at 5-degree intervals. The range of shaft movement is limited by mounting the shaft adapter:

Begin by loosening the shaft adapter from the damper shaft and remove the actuator from the damper shaft.

1. Remove clip.
2. Remove shaft adapter from the actuator.

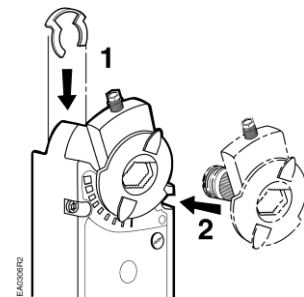

**Figure 16.**

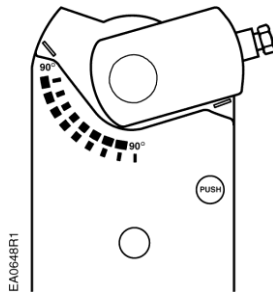

**Figure 17.**

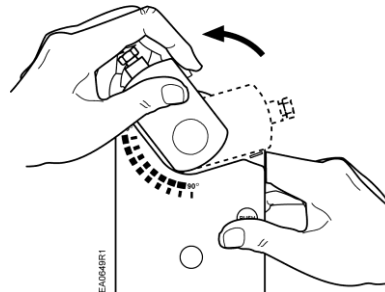

**Figure 18.**

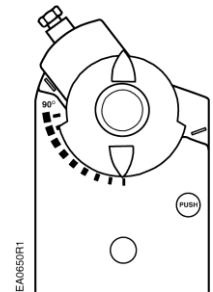

**Figure 19.**

3. Return the actuator gear train to the 0 position using the following steps for the clockwise or counterclockwise damper shaft rotation.

**Clockwise-to-open:**

- a. Insert the shaft adapter to the right as close as possible to the raised stop. See Figure 17.
- b. Hold down the **PUSH** button and rotate the shaft adapter to the left until it stops. See Figure 18.
- c. Release the **PUSH** button.
- d. If the shaft adapter is not resting against the left raised stop, remove the adapter and insert it against the left stop.
- e. Place the position indicator to the "0" position on the outside scale. See Figure 19.

### Mechanical range adjustment, continued

#### Counterclockwise-to-open:

- a. Insert the shaft adapter to the left as close as possible to the raised stop.
  - b. Hold down the **PUSH** button and rotate the shaft adapter to the right until it stops.
  - c. Release the **PUSH** button.
  - d. If the shaft adapter is not resting against the right raised stop, remove the adapter and insert it against the right stop.
  - e. Place the position indicator to **0** on the inside scale.
4. Determine the angle of rotation for the damper blade shaft. Subtract that amount from 90°.
  5. Remove the shaft adapter and insert it with the position indicator pointing to the mark on the scale calculated in the previous step. See Figure 20.
  6. Attach the clip.
  7. Rotate the damper blade shaft to its **0** position.
  8. Return the actuator to the damper shaft and tighten the shaft adapter to the damper shaft.

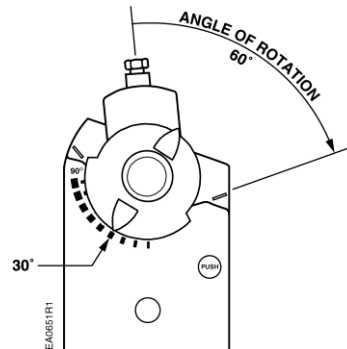

Figure 20. Mechanical Range Adjustment.

### Reversing the position indicator

Reverse the position indicator so that the counterclockwise 0 to 90 scale is visible.

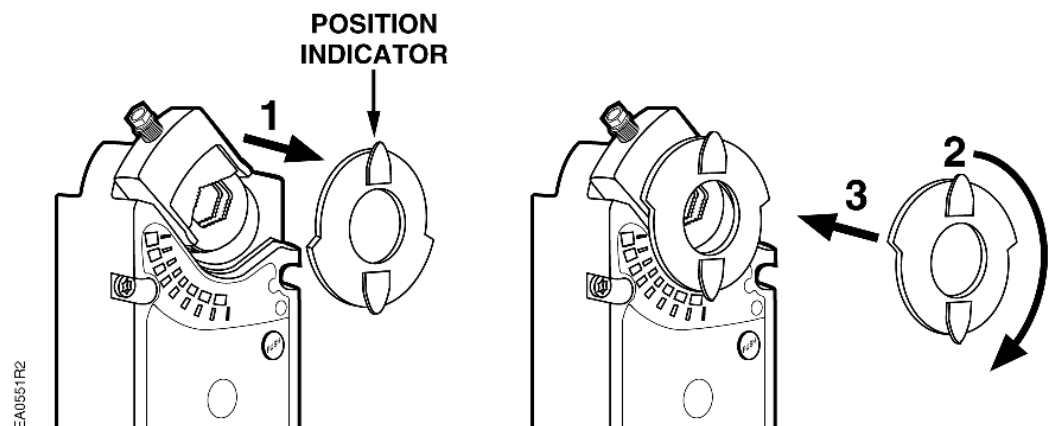

Figure 21. Position Indicator.

## Wiring

All wiring must conform to NEC and local codes and regulations.

Use earth ground isolating step-down Class 2 transformers. Do not use autotransformers.

The maximum rating for a Class 2 step-down transformer is 100 VA. Determine the supply transformer rating by summing the VA ratings of all actuators and all other components used.

It is recommended that one transformer does not power more than 10 actuators.



**WARNING:**

Mixed switch operation is not permitted to the switching outputs of both auxiliary switches (A and B).

Either AC line voltage from the same phase must be applied to all six outputs of the dual auxiliary switches, or UL-Class 2 voltage must be applied to all six outputs.

**NOTE:** With plenum cables, only UL-Class 2 voltage is permitted.



**CAUTION:**

Do not parallel wire GBB13x or GIB13x actuators with other type of actuator including GBB/GIB actuators with date codes earlier than 501.

## Wire Designations

Each wire has the standard symbol printed on it. See Table 2.

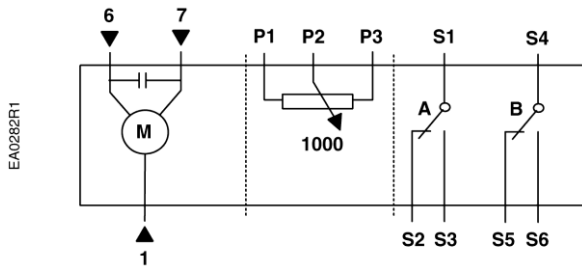

Figure 22. 24 Vac with Auxiliary Switches.

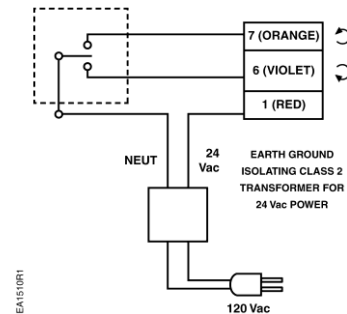

Figure 23. 24 Vac, Floating Control.

Table 2. Wire Designations.

Standard Symbol	Function	Terminal Designations	Color
1	Supply (SP)	G	Red
6	Control signal clockwise	Y1	Violet
7	Control signal counterclockwise	Y2	Orange
S1	Switch A – Common	Q11	Gray/red
S2	Switch A – Normally Closed	Q12	Gray/blue
S3	Switch A – Normally Open	Q14	Gray/pink
S4	Switch B – Common	Q21	Black/red
S5	Switch B – Normally Closed	Q22	Black/blue
S6	Switch B – Normally Open	Q24	Black/pink
P1	Feedback Potentiometer 0 to 100% P1 – P2	a	White/red
P2	Feedback Potentiometer Common	b	White/blue
P3	Feedback Potentiometer 100 to 0% P3 – P2	c	White/pink

---

## Start-Up/ Commissioning

1. Check the Operation:
    - a. Connect wires 1 (red), 6 (violet), and 7 (orange) to the actuator.
    - b. Apply a control signal (24 Vac) to wires 1 (red) and 6 (violet).
    - c. Allow the actuator shaft coupling to rotate from 0 to 90°.
    - d. Stop applying a control signal to wires 1 (red) and 6 (violet).
    - e. Apply a control signal (24 Vac) to wires 1 (red) and 7 (orange).
    - f. Allow the actuator shaft coupling to rotate from 90 to 0°.
- 

2. Check the Feedback:
  - a. Set the DMM dial to ohms.
  - b. Connect wires P1 and P2 to the DMM. The DMM should indicate a resistive value.
  - c. Apply a control signal (24 Vac) to wires 1 (red) and 6 (violet).  
The reading of the DMM should increase.
  - d. Stop applying a control signal to wires 1 (red) and 6 (violet).
  - e. Connect wires P2 and P3 to the DMM. The DMM should indicate a resistive value.

Apply a control signal (24 Vac) to wires 1 (red) and 7 (orange). The reading of the DMM should increase.

---

3. Check the Auxiliary Switch A:
    - a. Set the DMM dial to ohms (resistance) or continuity check.
    - b. Connect wires S1 and S3 to the DMM. The DMM should indicate an open circuit or no resistance.
    - c. Apply a control signal (24 Vac) to wires 1 (red) and 6 (violet).  
The DMM should indicate contact closure as the actuator shaft coupling reaches the setting of switch A.
    - d. Stop applying a control signal to wires 1 (red) and 6 (violet).
    - e. Connect wires S1 and S2 to the DMM. The DMM should indicate an open circuit or no resistance.
    - f. Apply a control signal (24 Vac) to wires 1 (red) and 7 (orange).  
The DMM should indicate contact closure as the actuator shaft coupling reaches the setting of switch A.
- 

4. Check the Auxiliary Switch B:
    - a. Set the DMM dial to ohms (resistance) or continuity check.
    - b. Connect wires S4 and S6 to the DMM. The DMM should indicate an open circuit or no resistance.
    - c. Apply a control signal (24 Vac) to wires 1 (red) and 6 (violet).  
The DMM should indicate contact closure as the actuator shaft coupling reaches the setting of switch B.
    - d. Stop applying a control signal to wires 1 (red) and 6 (violet).
    - e. Connect wires S4 and S5 to the DMM. The DMM should indicate an open circuit or no resistance.
    - f. Apply a control signal (24 Vac) to wires 1 (red) and 7 (orange).  
The DMM should indicate contact closure as the actuator shaft coupling reaches the setting of switch B.
-

**Service**



**WARNING:**

Do not open the actuator.  
 If the actuator is inoperative, replace the unit.

**Troubleshooting**



**WARNING:**

To avoid injury or loss of life, pay attention to any hazardous voltage, (for example, 120 Vac) when performing checks.

Check that the wires are connected correctly.

1. Connect wires 1 (red) and 6 (violet) to a Digital Multimeter (DMM) with the dial set at Vac. Apply a control signal (24 Vac) to wires 1 (red) and 6 (violet) to verify that the operating voltage is within range.
2. Next connect wires 1 (red) and 7 (orange) to a DMM with the dial set at Vac. Apply a control signal (24 Vac) to wires 1 (red) and 7 (orange) to verify that the operating voltage is within range.
3. If the actuator is not working, check the damper for blockage. If blocked, remove the obstacle and cycle the actuator power off and on. The actuator should resume normal operating mode.

**Dimensions**

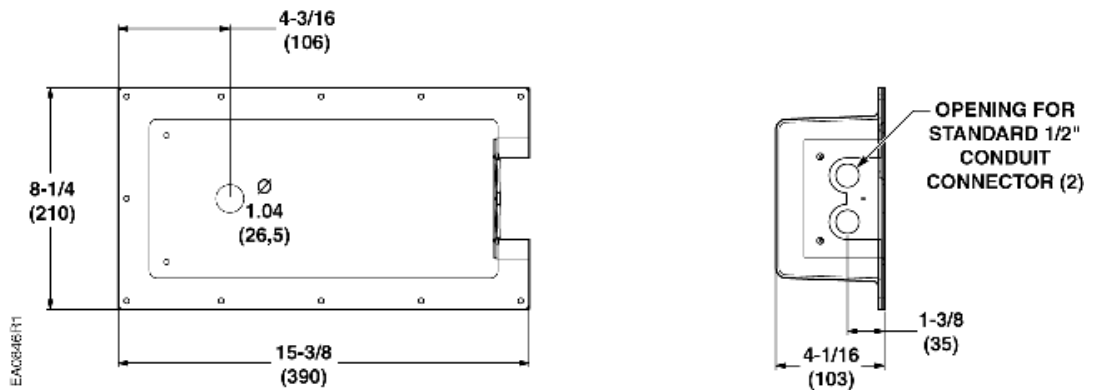

**Figure 24. Dimensions of the ASK75.1U Weather Shield in Inches (Millimeters).**

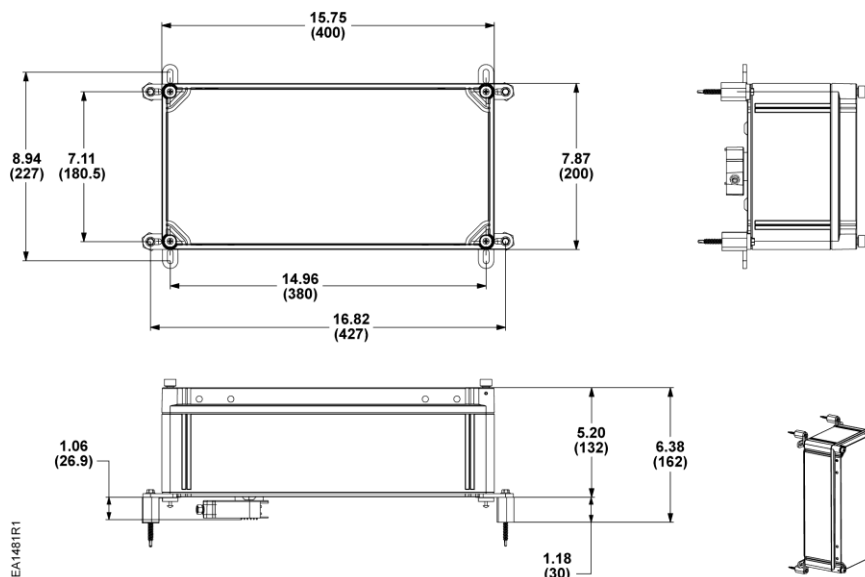

**Figure 25. Dimensions of the ASK75.7U Weather Shield in Inches (Millimeters).**

## Dimensions, Continued

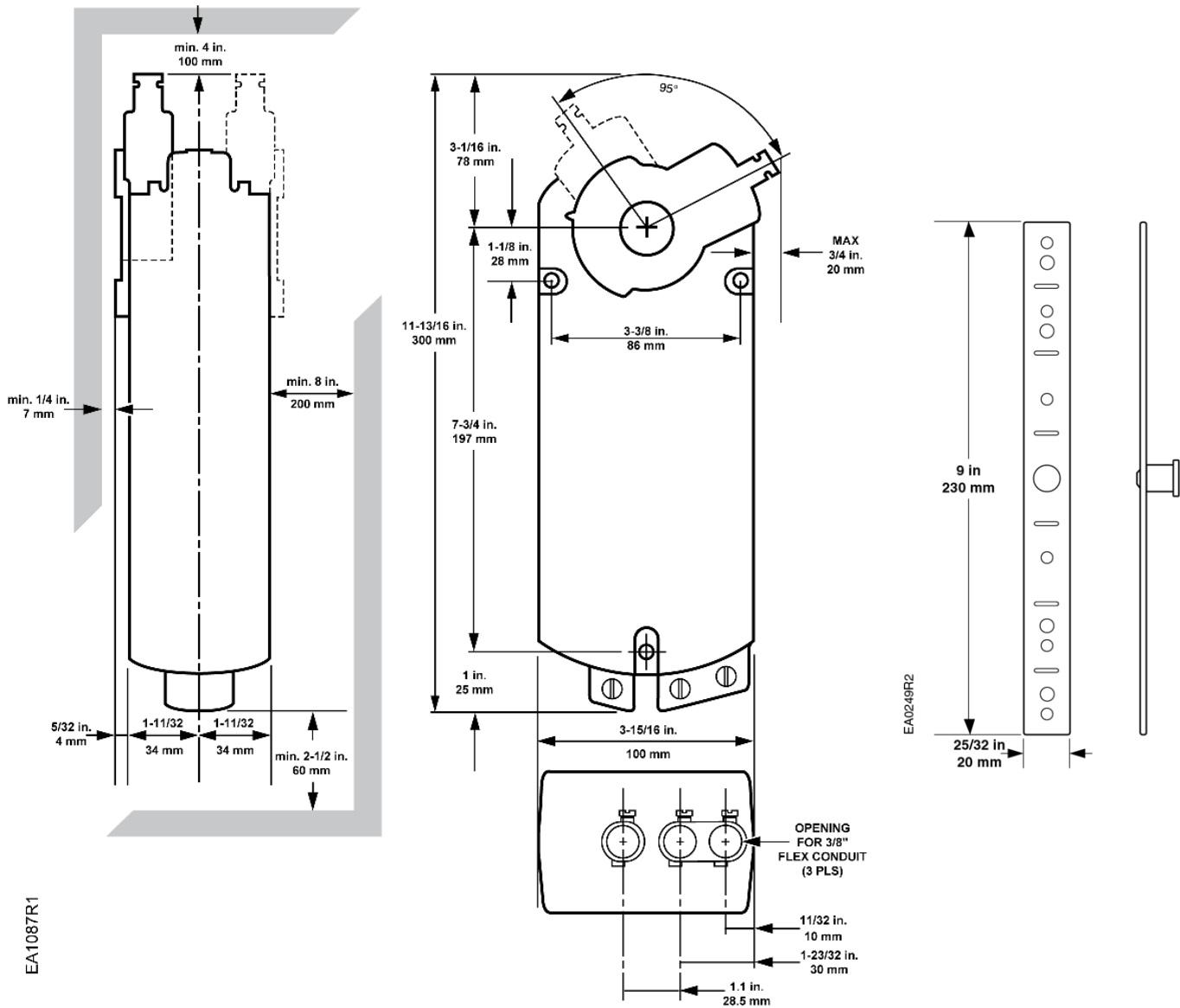

Figure 26. Dimensions of the GBB/GIB Actuator and Mounting Bracket in Inches (Millimeters).

EA1087R1

Information in this publication is based on current specifications. The company reserves the right to make changes in specifications and models as design improvements are introduced. OpenAir is a registered trademark of Siemens Schweiz AG. Product or company names mentioned herein may be the trademarks of their respective owners. © 2019 Siemens Industry, Inc.