

Powermite 599 Series

MT Series 2-inch Pneumatic Valve Actuator

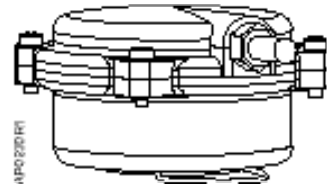

Description The Powermite 599 Series MT Series 2-inch pneumatic valve actuator is designed for use with the Powermite 599 Series MT Series terminal unit valves with a 7/32-inch (5.5 mm) stroke.

-
- Features**
- Low profile
 - Freely rotates to aid tubing installation
 - Easy installation and removal
 - All metal housing

Application These 2-inch pneumatic actuators are designed to be used on Powermite MT Series terminal unit valves requiring a minimum of 67 pounds force (300N). They can be used in liquid and steam service applications.

Product Number	599 -01088	Actuator Prefix code when combining with a
		10 to 15 psi spring range valve 256
		3 to 8 psi spring range valve 257
		8 to 13 spring range valve 258

Ordering Information To order a complete valve plus actuator assembly from the factory, combine the actuator prefix code with the suffix of the valve product number. See *Technical Bulletin (TB) 251* (155-306P25) for selection procedures.

To order an actuator only, use the product number listed above

Specifications	Effective diaphragm area	3.4 inch ² (22 cm ²)
	Diaphragm material	Silicone
	Nominal spring range	Valve dependent
	Span	5 psi (34 kPa) valve dependent
	Nominal stroke	7/32-inch (5.5 mm)
	Maximum diaphragm pressure	35 psi (241 kPa)
	Air Connection	1/8" N.P.T. fitting for 1/4-inch OD plastic tubing
	Ambient temperature	
	Transportation	-40 to 180°F (-40 to 82°C)
	Operating	35 to 120°F (-2 to 49°C)

**Specifications,
Continued**

Mounting location	NEMA 1 (interior only)
Dimensions	See Figure 2
Weight	0.43 lb (0.2 kg)

Service Kit

Diaphragm replacement kit (Package of five)	656-736
---	---------

Operation

The control air signal upon the diaphragm causes the valve to modulate whenever the air pressure is within the spring range of the valve.

**Mounting and
Installation**

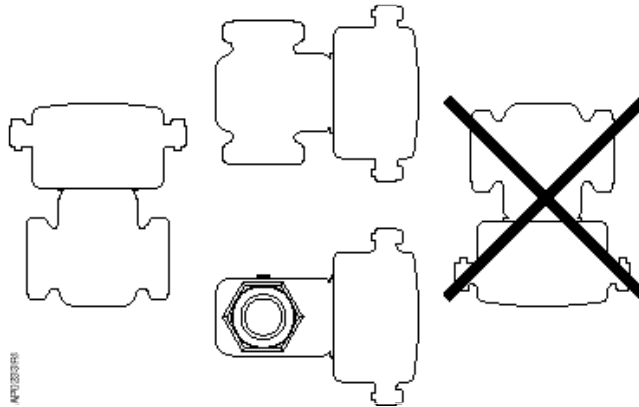

Figure 1. Acceptable Mounting Positions.

Allow 8 inches (200 mm) headroom and 6 inches (150 mm) on either side of the actuator.

For best performance install the actuator vertically above the valve. The actuator can be installed in any position between vertical and horizontal. We do not recommend installing the actuator below horizontal or up side down. See Figure 1 for allowable mounting positions.

Complete instructions for field mounting the actuator are included with the actuator.

Service

Diaphragm replacement

Complete instructions are included in the diaphragm replacement kit.

Dimensions

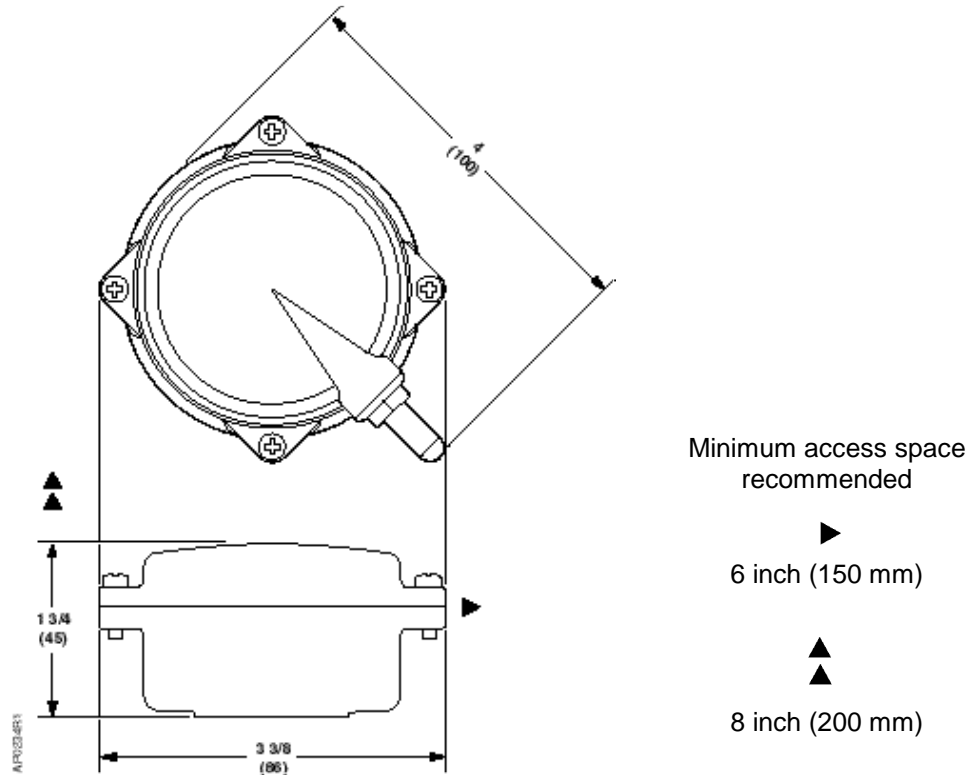

Figure 2. Dimensions in inches. Millimeters in parentheses.

Actuator Details

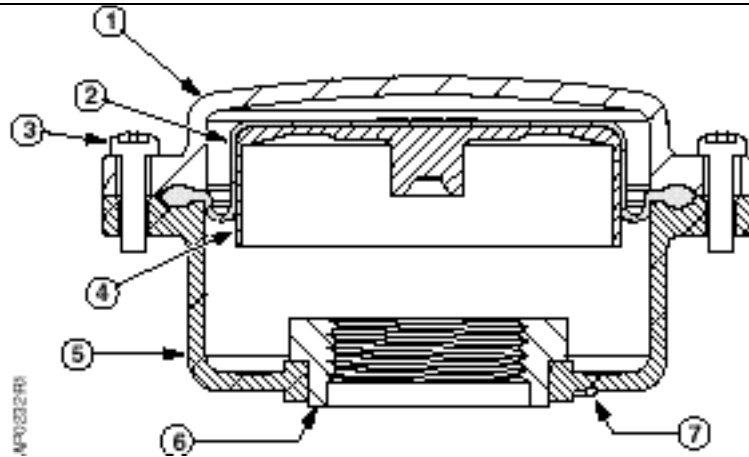

Figure 3. Powermite AP 599 Series 2-inch Pneumatic Valve Actuator.

Table 1. Parts of the Actuator. See Figure 3.

Item	Description	Q'ty	Material
1	Upper housing	1	Aluminum
2	Diaphragm	1	Silicone
3	Thread forming screw	4	Zinc plated steel
4	Piston cup	1	Aluminum
5	Lower housing	1	Aluminum
6	Lower housing retaining nut	1	Brass
7	Retaining clip	1	Galvanized steel
Not shown	1/8" N.P.T. fitting for 1/4 OD plastic tubing	1	Brass

Information in this publication is based on current specifications. The company reserves the right to make changes in specifications and models as design improvements are introduced. Product or company names mentioned herein may be the trademarks of their respective owners.
 © 2006 Siemens Industry, Inc.