

Powers™ Controls No. 3 Pneumatic Damper Actuator

Product Description

The No. 3 Pneumatic Damper Actuator is a compact, totally enclosed, rolling diaphragm type actuator designed for modulating or two-position actuation of dampers or air valves.

Required Tools

- Flat-blade screwdriver
- Adjustable crescent wrench
- Pliers

Prerequisites

- Ensure all kits are ordered and available for installation. Kits are listed with each mounting application.
- Have the damper manufacturer drill the mounting holes.

Expected Installation Time

28 minutes

Product Numbers

Description	Mounting Style	Part No.		
		Nominal Spring Range		
		3-7 psi (21-48 kPa)	5-10 psi (35-69 kPa)	8-13 psi (55-90 kPa)
Actuator	Front	331-4310	331-4510	331-4810
Actuator, bracket	Fixed	331-4313	331-4513	331-4813
Actuator, bracket, clevis	Fixed	331-4314	331-4514	331-4814
Actuator, integral pivot	Pivot	331-4312	331-4512	331-4812
Actuator, integral pivot with pivot post *	Extended shaft	331-4311	331-4511	331-4811
Actuator, integral pivot with pivot post *	Extended shaft kit with positioning relay	—	—	332-4811
Actuator, bracket, ball joint connector	Fixed	—	331-4531	331-4831
Actuator, bracket, ball joint connector, and positioning relay	Fixed	—	—	332-4831
Extended shaft with 90° barb fitting (for fume hood controller applications)	Extended shaft	—	—	546-00020

* Mounted on plate for extended shaft with clevis and crank for 3/8-inch (10-mm), 7/16-inch (11-mm), or 1/2-inch (13-mm) diameter shaft.

NOTE: When the actuator is ordered with Extended Shaft mounting, the mounting plate, pivot post and hardware, clevis, damper crank, rocker arm, and all screws/nuts are included. Order other frame mounting accessories as required if not supplied by damper manufacturer.

Installation

Extended Shaft Mounting – Pivot Actuator

Actuators: 331-4311, 331-4511, 331-4811, or 332-4811.

These assemblies are designed for 90° damper rotation.

NOTE: Clevis mounts in Crank Radius Hole No. 6 for 90° damper rotation.

- Slip the 9/16-inch (14 mm) diameter hole in the mounting plate over the damper shaft (Figure 1).
- Slip the crank over the 3/8 through 1/2-inch (10 through 13-mm) diameter damper shaft (Figure 2).
- Position the mounting plate (Table 1) and attach it to the duct with four screws.

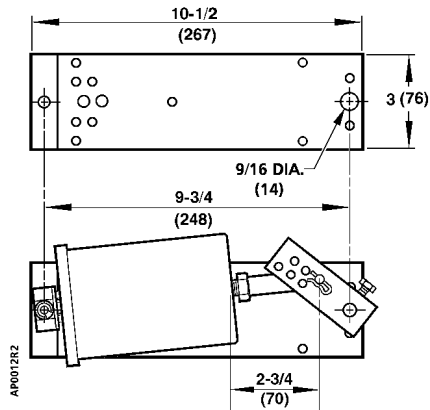
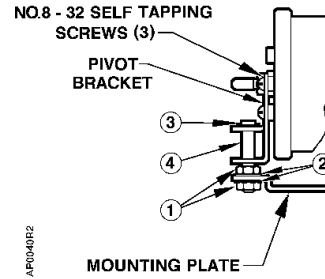
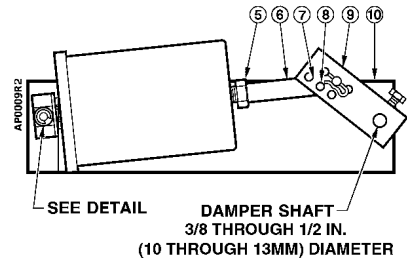

Figure 1. Mounting Plate and Extended Shaft Mounting. Dimensions shown in Inches (Millimeters).

Table 1. Damper Blade Rotation.

Actuator Position in Relation to Damper Shaft	Crank Position in Relation to Damper Shaft	Rotation of Damper Blade on Pressure Increase
Left	Above	Clockwise
	Below	Counterclockwise
Right	Above	Counterclockwise
	Below	Clockwise



Item	Description	Item	Description
1	Nuts (2)	6	Clevis
2	Lock Washers (2)	7	Hitch Pin
3	E-ring	8	Clevis Pin
4	Pivot Shaft	9	Crank Assembly Kit No. 331-941
5	Nut	10	Actuator Mounting Plate

Figure 2. Extended Shaft Mounting with Pivot.

Extended Shaft Mounting – Fixed Actuator

For Actuators 331-4314, 331-4514 or 331-4814, order Linkage Kit 331-958.

For Actuators 331-4313, 331-4513 or 331-4813, order Clevis 333-207 and Linkage Kit 331-958.

- Determine the direction of the damper shaft rotation (clockwise or counterclockwise) on an increase in pressure to the actuator.
- Determine the angle of rotation required for the damper to move from closed to full open.

NOTE: Since the actuator stroke is 2-3/8 inches (6 cm) and the angle of rotation is known, the crank radius can be determined from the graph in (TB 181 Maximum Thrust Ratings of Pneumatic Damper Actuators (155-219P25) or use Table 2.

Extended Shaft Mounting – Fixed Actuator, Continued

3. Attach the link to the crank at the radius value determined in Step 2.
4. Attach the clevis and other end of the linkage to the actuator shaft (Figure 3).
5. The normal position of the damper (open or closed) and its direction of rotation (CW or CCW) will determine the location of the actuator and linkage assembly (Table 1 and Figure 3).
6. Attach an airline or Baumanometer (squeeze bulb) to the actuator and increase pressure until the actuator shaft moves one half of its stroke, 1-3/16 inches (3 cm). Select the correct location for the actuator assembly as determined in Step 5.
7. Slip the crank over the damper shaft and position the assembly so that the actuator shaft and link are straight and perpendicular to the crank.
8. Mark and attach the actuator bracket to the duct at this location. If this installation procedure is followed, there will be no problem with linkage scissoring or locking up.

The installation is now complete.

Table 2. Crank Radius Connection.

Dimensions		Application	Crank Radius Connection	Crank Hole Number
X	Y			
7-7/8 in. (200 mm)	1-3/16 in. (30 mm)	2-3/8 in. (60 mm) stroke 90° rotation	1-11/16 in. (43 mm)	6
7-7/8 in. (200 mm)	2-1/16 in. (52 mm)	2-3/8 in. (60 mm) stroke 60° rotation	2-3/8 in. (60 mm)	5

NOTE: Crank Radius Holes No. 1 through 4 are used for No. 4 and No. 6 Pneumatic Damper Actuators only.

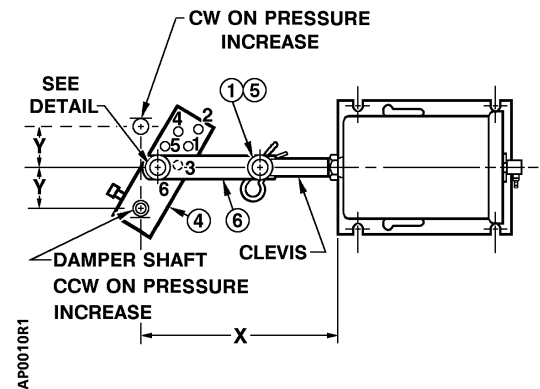
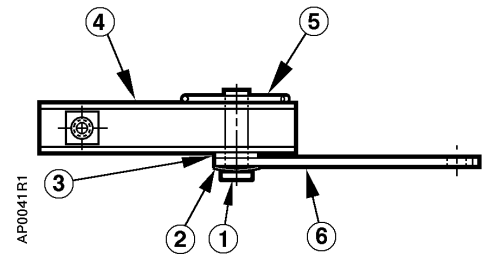

Item	Description	Item	Description
1	Clevis Pin	4	Crank with Set Screw
2	Spring Washer	5	Hitch Pin
3	Washer, Nylon	6	Link, 4 inches (102 mm) long

Figure 3. Fixed Mounted Actuator Assembly with Linkage Kit 331-958.

References

Document	Part Number
AP 331-1 No. 3 Pneumatic Damper Actuator Technical Instructions	155-146P25
TB 181 Maximum Thrust Ratings of Pneumatic Damper Actuators Technical Bulletin	155-219P25

Information in this publication is based on current specifications. The company reserves the right to make changes in specifications and models as design improvements are introduced. Powers is a trademark of Siemens Industry, Inc. Product or company names mentioned herein may be the trademarks of their respective owners. © 2009-2021 Siemens Industry, Inc.