

# 599 Series Zone Valve Actuator

## SSA/P Series 24 Vac Electronic Valve Actuator: Floating or 0 to 10 Vdc Control Fail-in-Place

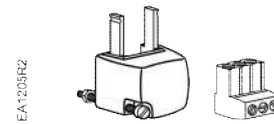
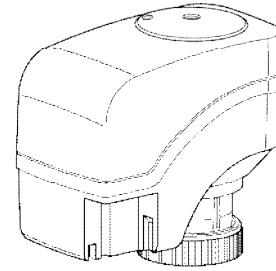

### Description

The 599 Series SSA/P Electronic Valve Actuator requires a 24 Vac power supply and receives a 0 to 10 Vdc or a floating control signal to control a valve. This actuator is designed to work with 599 Series Zone Valves with a 1/10-inch (2.5 mm) stroke and a threaded valve bonnet that fits the actuator.

### Features

- Direct-coupled installation without tools
- Manual override with hex wrench
- Visual position indication

### Application

For use in heating and cooling HVAC applications with Siemens 599 Series Zone Valves that need 24 lb (105N) nominal force.

### Product Number



Part Number	Description		Prefix Code
SSA81U	24 Vac	Floating	244
SSA61U		0 to 10 Vdc	Normally Closed
SSP61U			Normally Open

### Ordering Information

To order a complete valve plus actuator assembly from the factory, combine the actuator prefix code with the suffix of the valve product number.

To order a single actuator, use the product number (for example, SSA61U).

## Warning/Caution Notations

<b>WARNING</b>		Personal injury/loss of life may occur if you do not perform a procedure as specified.
<b>CAUTION</b>		Equipment damage may occur if you do not perform a procedure as specified.

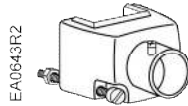
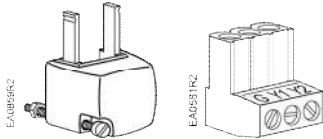
<b>Specifications</b>		<u>SSA81U</u>	<u>SSA/P61U</u>
<b>Power supply</b>	Operating voltage	24 Vac $\pm$ 20%	24 Vac $\pm$ 20%
	Frequency	50/60 Hz	50/60 Hz
	Power consumption	0.8 VA	2.5 VA
<b>Function</b>	Running time		
		SSA81U	150 seconds
		SSA/P61U	34 seconds
	Nominal stroke		1/10-inch (2.5 mm)
	Nominal force		24 lb (105N)
<b>Ambient conditions</b>	Ambient temperature		
	Operation		41°F to 122°F (5°C to 50°C)
	Transport and storage		-13°F to 158°F (-25°C to 70°C)
<b>Agency certification</b>			
<b>CE Conformance</b> <b>UL</b>	EMC directive		89/336/EEC
	Low Voltage direction		73/23/EEC
			UL873, cUL Certified to Canadian Standard C22.2 No. 24-93
<b>Miscellaneous</b>	Medium temperature		34°F to 230°F (1°C to 110°C)
	Dimensions Inches (mm)		3.26 H $\times$ 3.26 W $\times$ 1.9 D (82 $\times$ 83 $\times$ 48)
	Weight		9 oz (0.25 kg)
<b>Accessory</b>		<b>ASY97:</b> Conduit connector, quantity one (1).	
	<b>Figure 1. Conduit Connector.</b>		
<b>Service Kits</b>		<b>ASY99:</b> Terminal plug and terminal block cover for SSA81U, quantity one each.	
	<b>Figure 2. Terminal Plug and Block Cover</b>		

---

## Service Kits, Continued

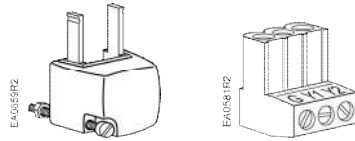

**Figure 3. Terminal Plug and Block Cover.**

**ASY100:** Terminal plug and terminal block cover for SSA/P61U, quantity one each.

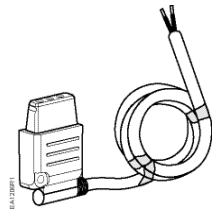

**Figure 4. Cable Connector.**

**ASY8L15:** Cable connector, 1.5m cable, **CE** rated, quantity one.

**ASY8L45:** Cable connector, 4.5m cable, **CE** rated, quantity one.

**NOTE:** These cables are not plenum rated.

---

**ASY98:** Replacement screw and nut for conduit connector quantity one (1).

---

## Operation

The actuators can be driven manually to any position between 0 and 1 with a 3 mm hex wrench. The control signal from the controller; however, will take priority over any manual position.

---

## Mounting and Installation

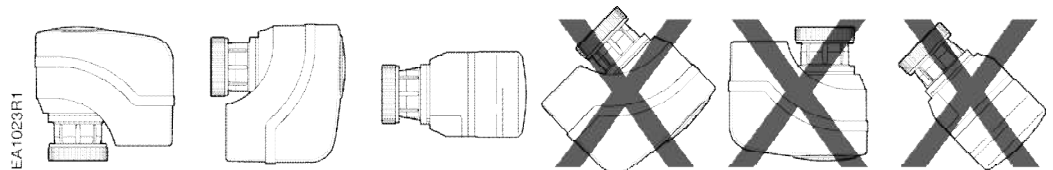

**Figure 5. Mounting Position.**

Mount the actuator in one of the allowable positions shown in Figure 5.

**NOTE:** Vertical is the recommended position.

When mounting the actuator in a plenum, the proper cable must be attached to meet local codes.

Allow 8-inches (200 mm) above the actuator and 8-inches (200 mm) behind the cable for service.

Installation Instructions are included with the actuator.

---

## Wiring

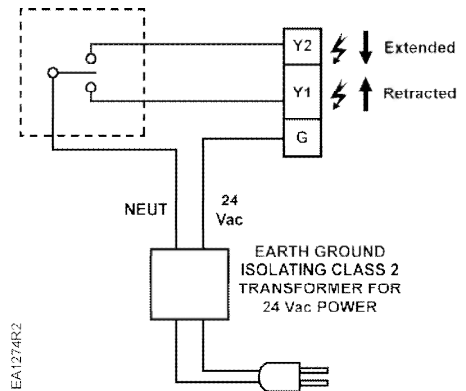
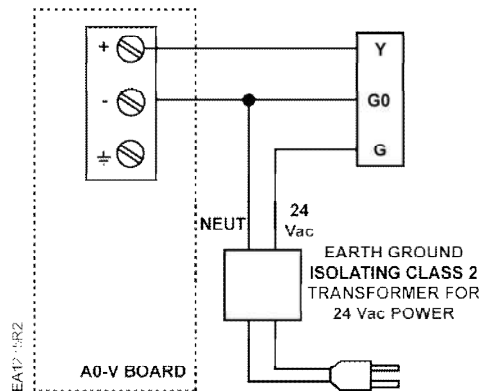

Figure 6. SSA/P61U Wiring Diagram. Figure 7. SSA81U Wiring Diagram.

- Do not use autotransformers.
- Use earth-ground isolating, step-down, Class 2, power supplies.
- Determine supply transformer rating by summing total VA of all actuators used.
- Use one transformer to power up to 10 actuators.



### WARNINGS:

- Wire connection G is 24 Vac HOT on the SSA/P61U, not neutral.
- G0 and G must be properly wired for correct function and full life of the actuator.

## Manual Override

The actuators can be driven manually to any position between **0** and **1** with a 3 mm hex key. The actuator will maintain its position until power is provided or restored. A control signal from the controller, however, will take priority over any manual position.

### NOTES:

- Do not perform a manual override while the power supply is connected: The actuator will not track properly when the control signal is applied. A short power-off/power-on sequence is recommended to recalibrate the actuator.
- To hold the actuator in the manually set position, the connecting cable must be unplugged.

### NOTE:

The **0** and **1** position markings are for reference only and not for stroke measurement.

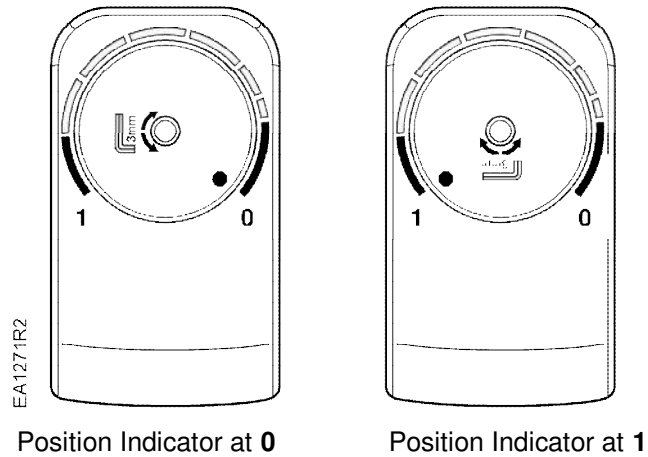

**Figure 8. Position Indicator.**

## Start-Up

Check the wiring and the position indication. See Figure 8 for referred positions "0" and "1" on the position indicator disc.

### SSA61U and SSA81U Normally Closed

- When the position indicator disc is at the "0" position the output shaft is extended (two-way valve closed).
- When the position indicator disc rotates to position "1", the output shaft is retracted (two-way valve open).

### SSP61U Normally Open

- When the position indicator disc is at the "0" position, the output shaft is *retracted* (two-way valve open).
- When the position indicator disc rotates to position "1", the output shaft is *extended* (two-way valve closed).



#### CAUTION:

The SSA61U and the SSP61U calibrate (calibration stroke) during start-up. Correct functioning cannot be guaranteed if the actuator is operated without a valve.

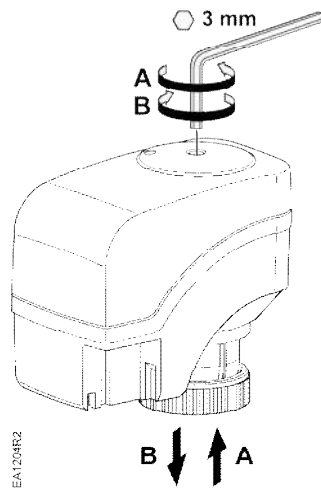

Figure 9. SSA61U and SSA81U  
Normally Closed.

- (A) Turn the hex wrench *counterclockwise* and spindle retracts.
- (B) Turn hex wrench *clockwise* and spindle extends.

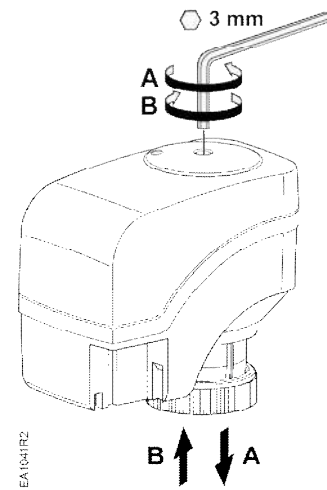

Figure 10. SSP61U  
Normally Open

- (A) Turn the hex wrench *clockwise* and spindle extends.
- (B) Turn hex wrench *counterclockwise* and spindle retracts.

---

## Troubleshooting

See *Wiring* for proper connections.

If the actuator does not provide full flow or full close off, check that the actuator is properly attached to the valve. If not, turn power off, tighten the bonnet ring on to the valve completely, and power up to recalibrate.

If the actuator becomes inoperative, replace it.

---

## Disposal

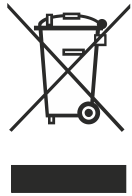

The device is considered electrical and electronic equipment for disposal in terms of the applicable European Directive and may not be disposed of as domestic garbage.

- Dispose of the device through channels provided for this purpose.
- Comply with all local and currently applicable laws and regulations.

---

## Dimensions

Inches (Millimeters)

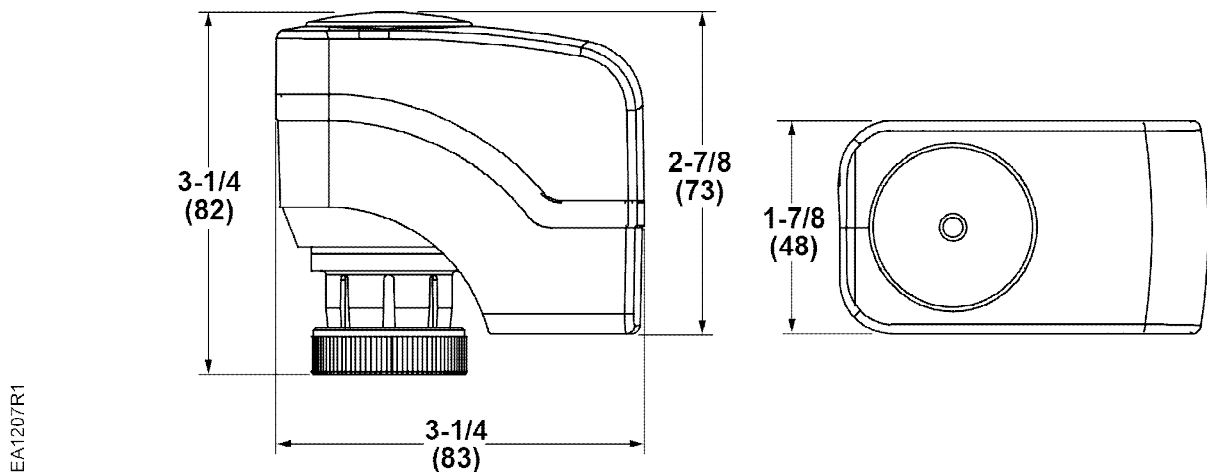

**Figure 11. Dimensions of the SSA/P Series Actuator in Inches (mm).**

---

## Service envelope

Minimum access space recommended:

8-inches (200 mm) above the actuator and beside the terminal plug.

---

Information in this publication is based on current specifications. The company reserves the right to make changes in specifications and models as design improvements are introduced. Product or company names mentioned herein may be the trademarks of their respective owners. ©2018 Siemens Industry, Inc.