

POWERS™ Controls

No. 3 Pneumatic Damper Actuator

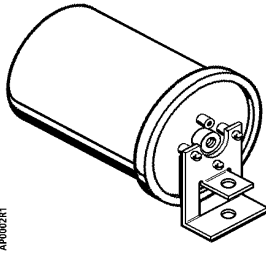

AP00381

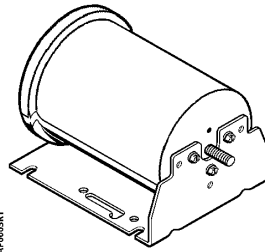

AP00381

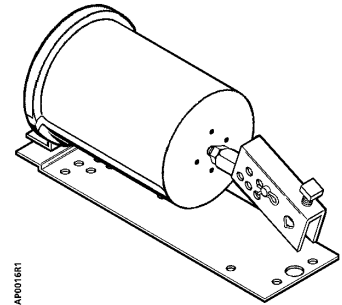

AP00381

331-4312 Pivot Mounting

331-4313 Fixed Mounting

331-4311 Extended Shaft Mounting

Description

The POWERS Controls No. 3 Pneumatic Damper Actuator is a compact, totally enclosed, rolling diaphragm-type actuator designed for modulating or two-position actuation of dampers or air valves.

Features

- All metal body construction
- Totally enclosed to protect internal parts
- Variety of spring ranges for sequencing
- Fixed or pivot mounting models
- Pivot mounting for extended shaft
- Positioning relay (optional)
- Variety of mounting/linkage kits for special applications
- Threaded shaft for easy mounting to accessory thread

Product Numbers

See Table 1.

Application

Typical applications are for control of mixing box dampers or air valves, and damper control for unit ventilators, unit conditioners and other HVAC applications.

These compact, totally enclosed actuators are easily installed either directly within the mixing box or unit enclosure, or externally, as required for each application.

Table 1. Product Numbers for No. 3 Pneumatic Damper Actuators.

Description	Mounting Style	Part No.		
		Nominal Spring Range		
		3-7 psi (21-48 kPa)	5-10 psi (35-69 kPa)	8-13 psi (55-90 kPa)
Actuator	Front	331-4310	331-4510	331-4810
Actuator, bracket	Fixed	331-4313	331-4513	331-4813
Actuator, bracket, clevis	Fixed	331-4314	331-4514	331-4814
Actuator, integral pivot	Pivot	331-4312	331-4512	331-4812
Actuator, integral pivot with pivot post *	Extended shaft	331-4311	331-4511	331-4811
Actuator, integral pivot with pivot post *	Extended shaft kit with positioning relay	—	—	332-4811
Actuator, bracket, ball joint connector	Fixed	—	331-4531	331-4831
Actuator, bracket, ball joint connector and positioning relay	Fixed	—	—	332-4831
Extended shaft with 90° barb fitting (for fume hood controller applications)	Extended shaft	—	—	546-00020

* Mounted on plate for extended shaft with clevis and crank for 3/8-inch (10-mm), 7/16-inch (11-mm), or 1/2-inch (13-mm) diameter shaft.

NOTE: When the actuator is ordered with extended shaft mounting, the mounting plate, pivot post and hardware, clevis, damper crank, rocker arm, and all screws/nuts are included. Order other frame mounting accessories as required if not supplied by damper manufacturer.

Specifications		
Effective diaphragm area		8 inches ² (51.6 cm ²)
Stroke		2-3/8 inches (6 mm) *
Housing (totally enclosed)		Aluminum
Stem		Plated steel
Diaphragm		Ozone resistant rubber
Spring		Steel
Cup		Zytel
Maximum air pressure		30 psig (210 kPa)
Type of mounting		Fixed or pivot
Thrust and torque rating		See Table 3
Agency Approvals		Complies with UL555 and UL555S
	* For special applications, an actuator stroke of 2-3/4 inch is available in 3 to 7, 5 to 10, or 8 to 13 psi (21 to 58, 35 to 69, or 55 to 90 kPa) spring ranges. Some models are UL Recognized Components under UL's Damper Actuator category (EMKU2), which covers pneumatic damper actuators intended to be employed on fire dampers and leakage rated dampers. Contact Siemens Smart Infrastructure, National OEM Sales and Marketing for information.	

Specifications, Continued	Nominal spring ranges	3 to 7 psi (21 to 50 kPa) 5 to 10 psi (35 to 69 kPa) 8 to 13 psi (55 to 90 kPa)
	Operating	
	Operating temperature	-20°F to 160°F (-29°C to 71°C)
	Air connection	Straight barb fitting for 1/4-inch OD plastic tubing installed in 1/8-inch NPT opening
Miscellaneous	Shipping Weight:	
	Basic actuator	1.3 lb (0.58 kg)
	Actuator with extended shaft mounting	3.1 lb (1.4 kg)
	Actuator with fixed bracket	2.5 lb (1.1 kg)
	Actuator with fixed bracket and clevis	2.7 lb (1.2 kg)
	Actuator with extended shaft mounting and Positioning Relay	4.8 lb (2.2 kg)
	Dimensions	See Figures 4 through 8

Accessories

Linkage kit, 4-inch link and crank	331-958
Linkage kit, 4-inch rod, ball joint and crank	331-947
Damper shaft crank, selectable radius, 45°, 60°, and 90°, angular rotation for 3/8 to 1/2-inch (10 to 13-mm) diameter damper shafts	331-941
Damper shaft crank, adjustable radius 3/4 to 2-7/8 inch (19 to 73 mm) for 1/2-inch (13-mm) diameter damper shafts	331-795
Damper shaft crank, adjustable radius 3/4 to 4-5/8 inch (19 to 177 mm) for 3/8-inch (9 mm) diameter damper shafts	331-805
Damper shaft extension, 1/2 × 9 inches long	333-042
Damper shaft extension, 1/2 inch shaft	331-631
Damper shaft extension Adapter, for 3/8 inch shaft	331-632
Pivot mounting kit (bracket and three mounting screws)	333-148
Pivot post	333-139
Fixed mounting bracket	331-916
Extended shaft mounting plate	331-033
Clevis, steel	333-207
Clevis, forged	331-292
Clevis pin	331-293
Clevis, frame mounting	331-653
Hitch pin	331-807
12-inch Damper actuator push rod	338-041
15-inch Damper actuator push rod	338-042
18-inch Damper actuator push rod	338-043
24-inch Damper actuator push rod	338-044
36-inch Damper actuator push rod	338-045
48-inch Damper actuator push rod	338-046
Damper blade rocker arm	333-034
Positioning relay	147-2000
Relay mounting kit	147-104

Table 3. Thrust Torque Ratings.

Nominal Spring Range	Maximum Thrust lb. (N)				Torque Rating* lb-in (Nm)			
	Full Stroke Forward			Spring Return (No Stroke) 0 psig (0 kPa)	Gradual Operation	2-Position Operation		
	15 psi (103 kPa)	18 psi (124 kPa)	25 psi (172 kPa)			15 psi (103 kPa)	18 psi (124 kPa)	25 psi (172 kPa)
3 to 7 psi (21 to 48 kPa)	64 (285)	88 (391)	144 (641)	24 (107)	10 (1.1)	20.2 (2.3)	20.2 (2.3)	20.2 (2.3)
5 to 10 psi (35 to 69 kPa)	40 (178)	64 (285)	120 (534)	40 (178)	10 (1.1)	33.6 (3.8)	33.6 (3.8)	33.6 (3.8)
8 to 13 psi (55 to 90 kPa)	16 (71)	40 (178)	96 (427)	64 (285)	10 (1.1)	53.8 (6.1)	53.8 (6.1)	53.8 (6.1)

* With maximum hysteresis of 2.5 psi (17.2 kPa) @ 90° rotation.

Sizing

The size and quantity of actuators required depends on several damper torque factors:

- Damper type (standard or low leakage)
- Quality of damper installation
- Number of damper sections
- Air velocity
- Static pressure
- Age of damper

To determine the correct actuator required for the installation:

- Obtain the damper torque ratings (lb-in/sq-ft) from the damper manufacturer.
- Determine the area of the damper.
- Calculate the total torque required to move the damper.
- Select the appropriate actuator(s).

Installation

Extended Shaft Mounting, Pivot Mounting

For Actuators 331-4311, 331-4511, 331-4811, or 332-4811. These assemblies are designed for 90° damper rotation.

NOTE: Clevis mounts in Crank Radius Hole No. 6 for 90° damper rotation.

1. Slip the 9/16-inch (14 mm) diameter hole in the mounting plate over the damper shaft (Figure 1).
2. Slip the crank over the 3/8 through 1/2-inch (10 through 13-mm) diameter damper shaft (Figure 2).
3. Position the mounting plate (Table 3).
4. Attach the mounting plate to the duct with four screws.

Installation, Continued

Table 3. Damper Blade Rotation.

Actuator Position in Relation to Damper Shaft	Crank Position in Relation to Damper Shaft	Rotation of Damper Blade on Increase of Pressure
Left	Above	Clockwise
	Below	Counterclockwise
Right	Above	Counterclockwise
	Below	Clockwise

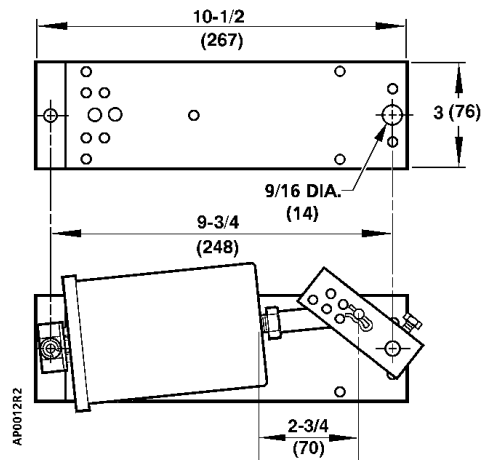
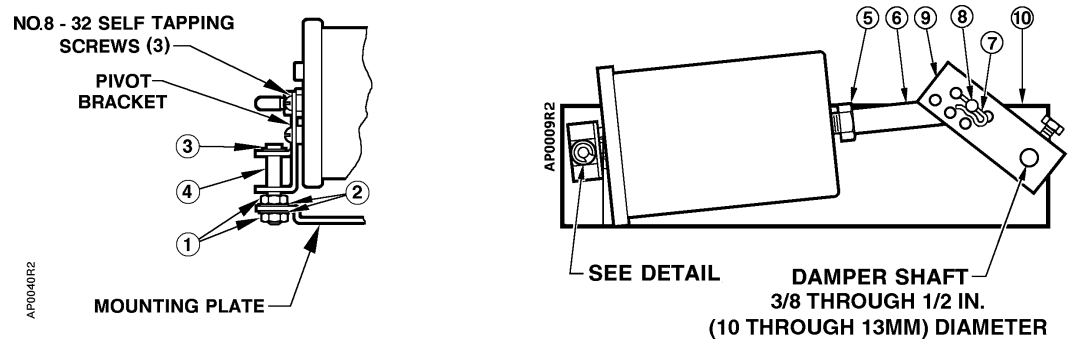

Figure 1. Mounting Plate and Extended Shaft Mounting.



Item	Description	Item	Description
1	Nut(s)	6	Clevis
2	Lock Washers (2)	7	Hitch Pin
3	E-ring	8	Clevis Pin
4	Pivot Post	9	Crank Assembly Kit No. 331-941
5	Nut	10	Actuator Mounting Plate

Figure 2. Extended Shaft Mounting with Pivot.

Installation, Continued

Extended Shaft Mounting, Fixed Actuator

For Actuators 331-4314, 331-4514, 331-4814 order Linkage Kit 331-958.

For Actuators 331-4313, 331-4513, 331-4813, order Clevis 333-207 and Linkage Kit 331-958.

1. Determine the direction of the damper shaft rotation (clockwise or counterclockwise) on an increase in pressure to the actuator.
2. Determine the angle of rotation required for the damper to move from closed to full open.

NOTE: Since the actuator stroke is 2-3/8 inch (6 cm) and the angle of rotation is known, the crank radius can be determined from the graph in *TB181 Maximum Thrust Ratings of Pneumatic Damper Actuators Technical Bulletin* (155-219P25) or use Table 4.

3. Attach the link to the crank at the radius value determined in Step 2.
4. Attach the clevis and other end of the linkage to the actuator shaft (Figure 3).
5. The normal position of the damper (open or closed) and its direction of rotation (CW or CCW) will determine the location of the actuator and linkage assembly (Table 3).
6. Attach an air line or Baumanometer (squeeze bulb) to the actuator and increase pressure until the actuator shaft moves one half of its stroke, 1-3/16 inch (3 cm). Select the correct location for the actuator assembly as determined in Step 5.
7. Slip the crank over the damper shaft and position the assembly so that the actuator shaft and link are straight and perpendicular to the crank.
8. Mark and attach the actuator bracket to the duct at this location. If this installation procedure is followed, there will be no problem with linkage scissoring or locking up.

The installation is complete.

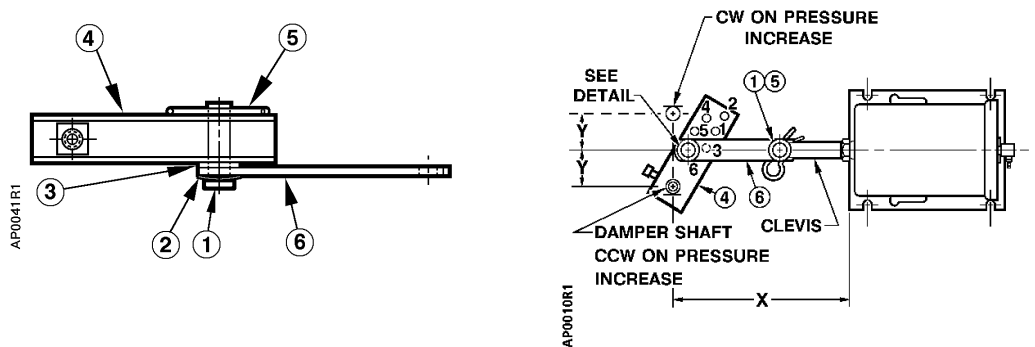

Item	Description	Item	Description
1	Clevis Pin	4	Crank with Set Screw
2	Spring Washer	5	Hitch Pin
3	Washer, Nylon	6	Link, 4 inches (102 mm) long

Figure 3. Fixed Mounted Actuator Assembly with Linkage Kit 331-958.

Installation, Continued

Table 4. Crank Radius Connection.

Dimensions		Application	Crank Radius Connection	Crank Hole Number
X	Y			
7-7/8 inch (200 mm)	1-3/16 inch (30 mm)	2-3/8 inch (60 mm) stroke 90 ° Rotation	1-11/16 inch (43 mm)	6
7-7/8 inch (200 mm)	2-1/16 inch (52 mm)	2-3/8 inch (60 mm) stroke 60 ° Rotation	2-3/8 inch (60 mm)	5

NOTE: Crank Radius Holes No. 1 through 4 are used for No. 4 and No. 6 Pneumatic Damper Actuators only.

Dimensions

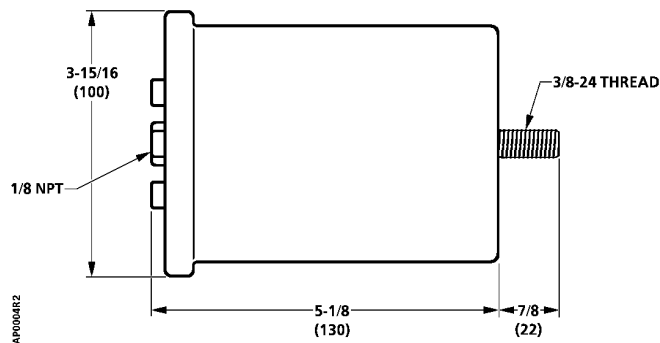

Figure 4. No. 3 Pneumatic Damper Actuator Dimensions. Dimensions are in Inches (Millimeters).

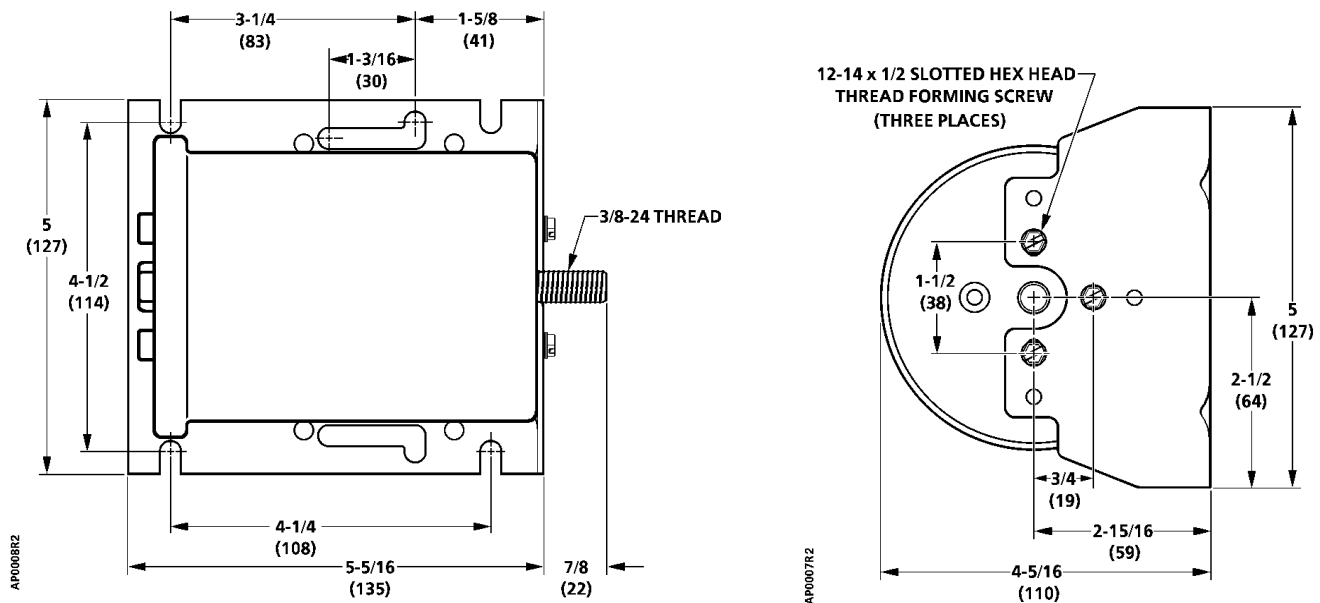

Figure 5. No. 3 Actuator with Fixed Mounting Bracket Dimensions. Dimensions are in Inches (Millimeters).

Dimensions, Continued

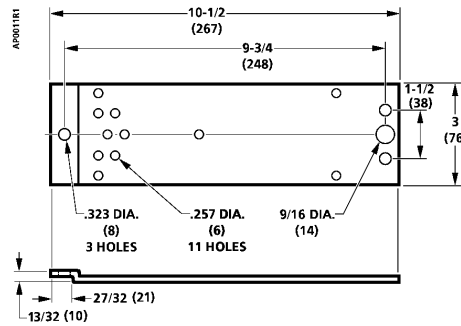

Figure 6. Extended Shaft Mounting Bracket Dimensions. Dimensions are in Inches (Millimeters).

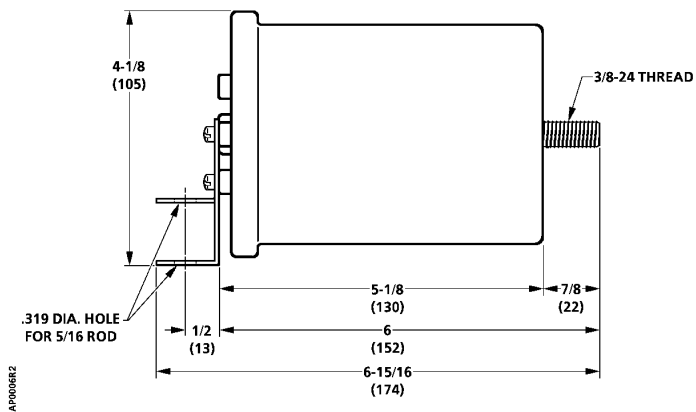
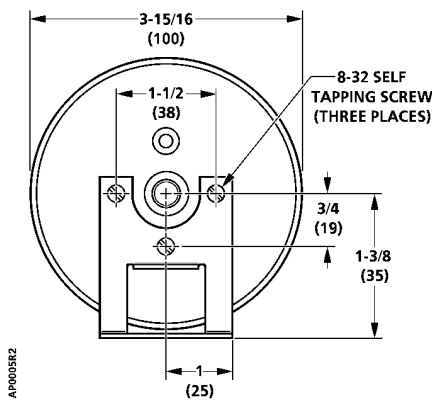

Figure 7. No. 3 Actuator with Pivot Mounting Bracket Dimensions. Dimensions are in Inches (Millimeters).

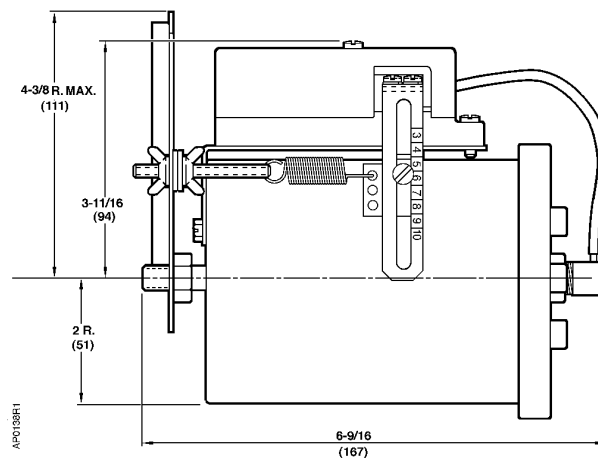

Figure 8. No. 3 Actuator with the RL 147 Positioning Relay Mounted Dimensions. Dimensions in Inches (Millimeters).

Information in this publication is based on current specifications. The company reserves the right to make changes in specifications and models as design improvements are introduced. POWERS is a registered trademark of Siemens Industry, Inc. Product or company names mentioned herein may be the trademarks of their respective owners. © 2008-2021 Siemens Industry, Inc.