

OpenAir™ GMA Series, Spring Return, 24 Vac/dc and 120 Vac, 62 lb-in, Direct-Coupled Electronic Damper Actuators

Product Number	Operating Voltage		Control				Cables		Built-In Control Options					
	24 Vac ±20%	24 Vdc ±15%	120 Vac ±10%	Modulating 0 to 10 Vdc	Modulating 2 to 10 Vdc	Floating	2-position	Standard	Plenum	Position Feedback	Dual Auxiliary Switches	Offset 0 to 5 Vdc Span 2 to 30 Vdc	Input Signal Inversion (Direct or Inverse Acting)	Feedback Signal Inversion
GMA121.1U	•						•	•						
GMA121.1P/B	•						•	•						
GMA121.1P	•						•	•						
GMA126.1U	•						•	•			•			
GMA126.1P	•						•	•			•			
GMA221.1U			•				•	•			•			
GMA226.1U			•				•	•			•			
GMA131.1U	•					•		•						
GMA131.1P	•					•		•						
GMA132.1U	•					•		•						
GMA136.1U	•					•		•			•			
GMA151.1U	•				•			•				•	•	
GMA151.1P	•				•			•				•	•	
GMA156.1U	•				•			•			•	•	•	
GMA156.1P	•				•			•			•	•	•	
GMA161.1U	•			•				•						
GMA161.1P	•			•				•						
GMA163.1U	•			•				•			•			
GMA163.1P	•			•				•			•			
GMA164.1U	•			•				•			•	•		
GMA166.1U	•			•				•			•	•		
GMA166.1P	•			•				•			•	•		

Description

The OpenAir direct-coupled, spring return electronic damper actuators provide modulating, two-position and three-position control of building HVAC dampers.

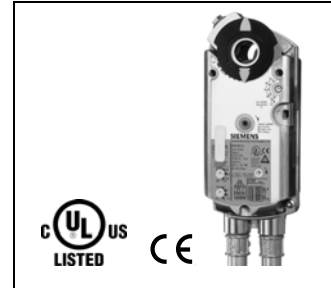

Features

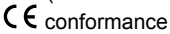
- Brushless motor technology
- Bi-directional fail-safe spring return
- Unique self-centering shaft coupling
- Models available with dual, independently adjustable auxiliary switches
- Floating control models available with feedback potentiometer
- All modulating control types include built-in feedback capability
- All metal housing
- Manual override
- Mechanical range adjustment capability
- Easily visible position indicator
- Precabled
- UL60730 (to replace UL873) and cUL (C22.2 No. 24-93) listed  conformance
- Small actuator footprint with 62 lb-in of torque
- 24 Vac/dc compatible

Technical Data

Runtime for 90°:	90 sec. operating
Spring Return:	15 sec. typical (<60 seconds max. at -25°F (-32°C))
Frequency:	50/60 Hz
Power consumption: 24 Vac/dc	
Running:	5 VA/3.5W
Holding:	4 VA/3W
Power Consumption: 120 Vac	
Running and holding:	≤7 VA/5W
Equipment rating (24V):	Class 2 per UL/CSA
Angle of rotation:	90° nominal, 95° max.
Shaft dimensions:	1/4 to 3/4-in. (6.4 to 20.5 mm) dia., 1/4 to 1/2-in. (6.4 to 13 mm) sq., 1-in. (25.4 mm) min. length
Operating temperature:	-25°F to 130°F (-32°C to 55°C)
Storage temperature:	-40°F to 158°F (-40°C to 70°C)
Ambient humidity:	95% rh (non-condensing)

Technical Data, continued

Enclosure:	NEMA 1
Precabled connection:	18 AWG, 3 ft (0.9 m) long
Agency listings:	UL60730 (to replace UL873) C-UL C22.2 No. 24-93
Material:	Die cast aluminum alloy
Gear lubrication:	Silicone free
Dimensions:	8-3/8" H × 3-1/4" W × 2-2/3" D (212 mm H × 83 mm W × 68 mm D)
Weight:	2.9 lb (1.3 kg)
Country of Origin	USA

Typical Specifications

Spring-return damper actuators shall be the direct-coupled type that requires no connecting linkages. These spring return actuators shall have a self-centering damper shaft coupling that assures concentric alignment of the actuator's output coupling with the damper shaft for <60 lb-in torque and be capable of direct mounting to a shaft up to a 3/4-inch in diameter. Actuators shall provide stall protection throughout the full range of rotation. All spring return actuators shall be capable of both clockwise and counterclockwise spring return fail-safe operation using a continuously engaged mechanical return spring that returns the actuator to a fail-safe position in <15 seconds in response to a loss of power. All actuators shall provide a means of manually positioning the output coupling in the absence of power. Dual, independently adjustable auxiliary switches are available for these actuators. All actuators must be precabled and provide an easily readable high contrast yellow on black position indicator. All actuators shall be CE conforming; UL60730 (to replace UL873) and CSA22.2 listed and manufactured under ISO 9002 and ISO 14000 procedures. Actuators shall be as manufactured by Siemens Industry, Inc.

Dimensions in Inches (Millimeters)

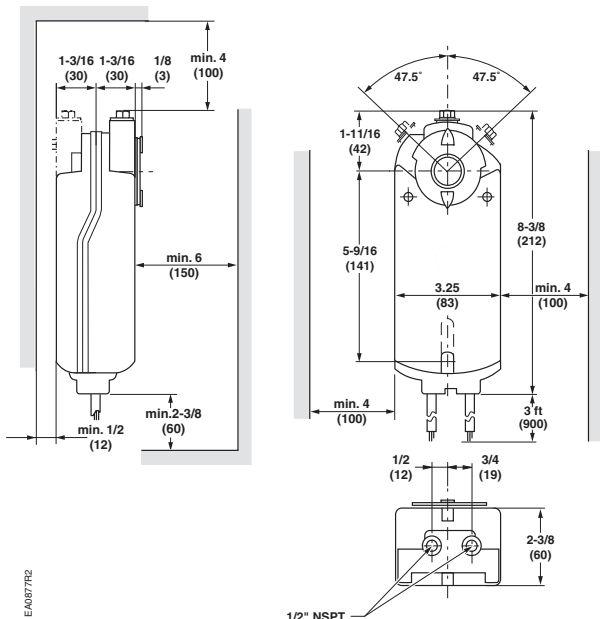

Wiring Diagrams

GMA12x, 2-Position, 24 Vac/dc:

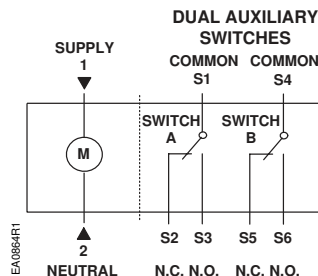

GMA22x, 2-Position, 120 Vac:

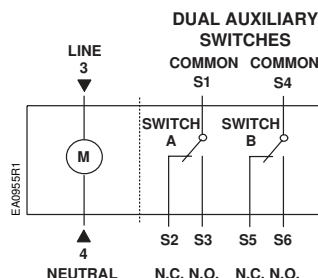

GMA13x, Floating, 24 Vac/dc:

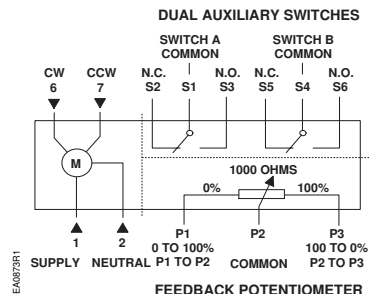

GMA16x, GMA15x; Modulating; 24 Vac/dc:

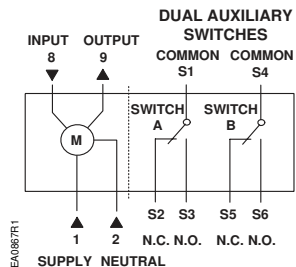

Information in this publication is based on current specifications. The company reserves the right to make changes in specifications and models as design improvements are introduced. OpenAir is a registered trademark of Siemens Schweiz AG. Product or company names mentioned herein may be the trademarks of their respective owners. © 2011 Siemens Industry, Inc.