

SIEMENS



Smart Thermostat RDS120-B Commissioning Guide



Table of Contents

1	Summary	3
1.1	Brief description	3
1.2	Inbox items.....	3
1.3	Associated Equipment	3
2	Installation	6
3	Setup wizard	10
4	Presence detection	11
4.1	Presence detection using the built-in PIR sensor	11
4.2	Approach detection	12
5	Changing system setup	14
6	Managing application settings	17
7	Disassembly	27
8	Appendices	28
8.1	Technical specifications	28
8.2	Cyber security disclaimer	28
8.3	Regulatory information	28
8.3.1	ISED Regulations (Canada)	28
8.3.2	FCC Regulations (USA)	29
8.4	EULA	29

1 Summary

1.1 Brief description

Smart Thermostat RDS120 is designed to control the heating/cooling system in apartments, single family homes, dormitories and other residential-type as well as light commercial spaces. Apart from traditional operations performed directly on the hardware unit, remote operations that use a mobile app are also allowed for your convenience.

1.2 Inbox items

Items	Quantity
Thermostat (front and rear)	1
Metal mounting plates (small & large)	2
Plastic frame	1
Set of screws and drywall anchors	1
Quick guide	1
Mounting instructions	1
Wiring decals	1
Activation code decal	1

1.3 Associated Equipment

Remote sensors

Sensor Type	Model Number	1k Ohm at 32°F Ni R	1k Ohm Pt RTD	Type 2 Thermistor	0-10 Vdc	Datasheet*
Room Temperature Sensors						
- Wall-mount	QAA2220.EWSN	x				149-714
	QAA2212.EWSN		x			149-714
	QAA2230.EWSN			x		149-714
	QAA2255.EWSN				x	149-714
- Flush-mount ¹⁾	540-984 (Metal)			x		149-956
	536-994A (Beige)			x		149-956
	536-994B (White)			x		149-956

Sensor Type	Model Number	1k Ohm at 32°F Ni R	1k Ohm Pt RTD	Type 2 Thermistor	0-10 Vdc	Datasheet*
- Duct-mount	QAM2030.010 (4")			x		149-915
Outdoor Temperature Sensors						
	QAC22	x				149-920
	QAC2012		x			149-920
	QAC2030			x		149-920
	QAC3161				x	149-920
Cable Temperature Sensors						
	QAP22	x				149-918
	QAP2012.150		x			149-918
	QAP1030.200			x		149-918
Room Humidity Sensors						
- Wall-mount with temperature	QFA3212.EWSN		x(T)		x (r.h.)	149-714
	QFA32SS.EWSN				x (T+r.h.)	149-714
- Duct-mount with temperature	QFM2160U				x (T+r.h.)	149-991
Indoor Air Quality Sensors						
- CO ₂	QPA2000				x	149-910
- VOC + CO ₂	QPA2002				x	149-910
	QPA2002D ¹⁾				x	149-910
- CO ₂ with temperature	QPA2060				x(CO ₂ +T)	149-910
	QPA2060D ¹⁾				x(CO ₂ +T)	149-910
- Duct-mount CO ₂	QPM2100				x	149-909
- Duct-mount VOC + CO ₂	QPM2102				x	149-909
- Duct-mount CO ₂ with temperature	QPM2160				x(CO ₂ +T)	149-909

* The documents can be downloaded from [Siemens US Download Center](#) by specifying the product number as shown in the above table.

1) With digital display

Replacement Part

Description	Model Number	Orderable Part Number
Plastic trim plate and metal mounting plate for 2" x 4" box (1 set)		ARG100.01
		S55772-T102

2 Installation

Mounting

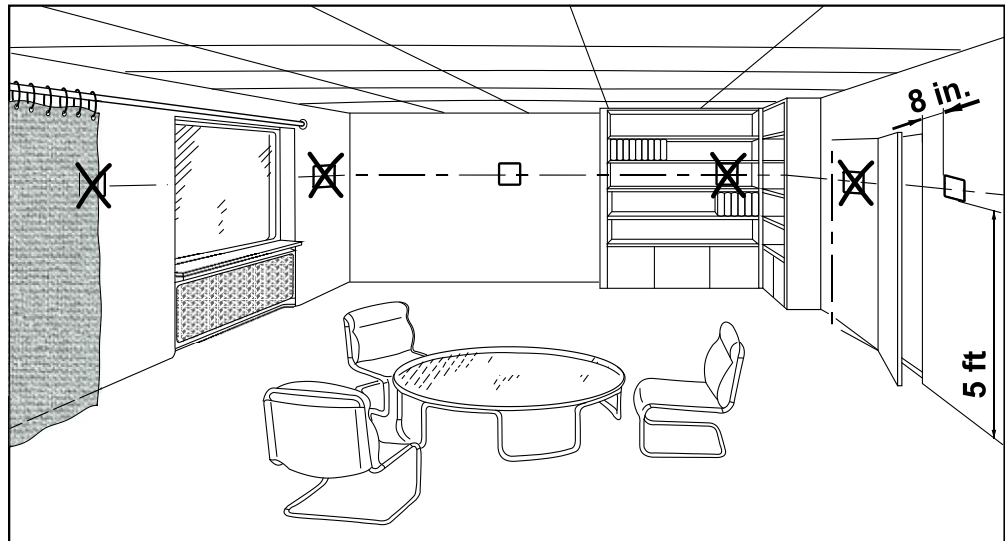

- The thermostat is designed for wall mounting.
- The recommended height is 5 feet above the floor.
- Do not mount the thermostat in recesses, shelves, behind curtains or doors, or above or near heat sources.
- Avoid direct exposure to sun and drafts.
- Seal the conduit and/or wall opening, as drafts can affect sensor readings.
- Observe maximum ambient conditions.

Installing the thermostat

1. Switch off power to the heating/cooling system at the breaker or system power switch.

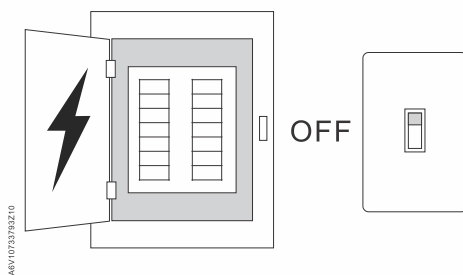

2. Remove the old thermostat from the wall with wires still connected.
3. Using the provided wire decals, label the existing wire connections. It is also helpful to take a picture of the current wire connections for subsequent reference.

X1	X2	Y1	Y2	RC	RH	RDS 1 2 0
X1	X2	Y1	Y2	RC	RH	
G	C	M	M	W1 O/B	W2 AUX	W3 UNIV
G	C	M	M	W1 O/B	W2 AUX	W3 UNIV

4. Disconnect all the labeled wires and then remove the old thermostat.

NOTICE! Do not discard the old thermostat in the trash if it contains mercury. Contact a thermostat recycling organization, for example, www.thermostat-recycle.org, for safe disposal of the old thermostat.
5. Check whether more wires are needed to bring 24 Vac power from the HVAC equipment to the thermostat. If yes, prepare the wires and label them accordingly.
6. Seal the conduit and/or wall opening to prevent entrance of cold or warm air and ensure accurate temperature readings by the internal sensor.
7. Install the mounting plate and power unit.
 - If you are mounting the thermostat directly on a wall, screw the small mounting plate enclosed with the thermostat snugly on the wall using a screwdriver, making sure that the mounting plate is placed correctly (the part with the upward arrow is placed on the top), and then screw the power unit on the mounting plate.

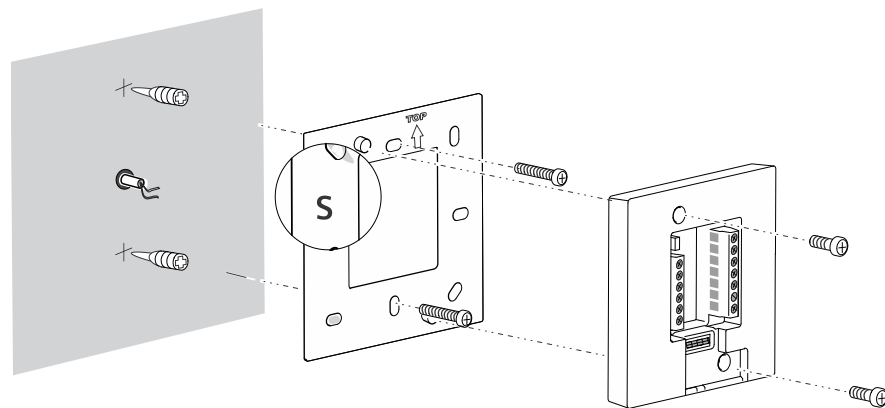

- If you are mounting the thermostat on a conduit box, install the metal mounting plate enclosed with the thermostat tightly on the conduit box (making sure that the upward arrow part is placed on the top), attach the plastic trim plate to the mounting plate, and secure by screws.

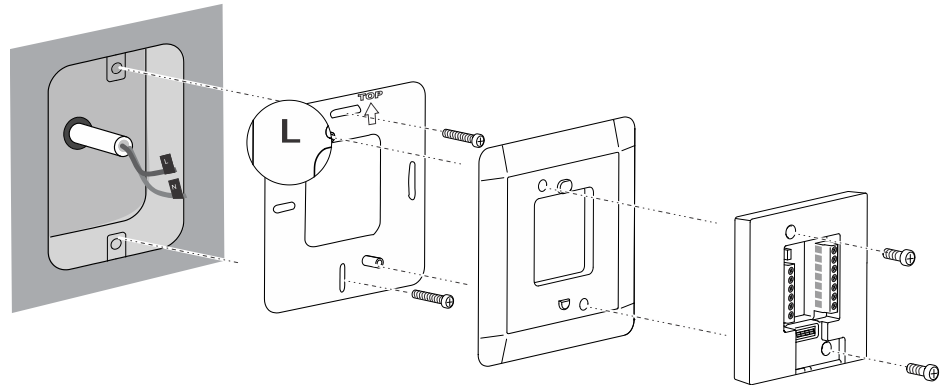

Tip: Before installing the power unit, it is highly recommended the labeled wires be connected to the terminals snugly according to the thermostat terminal designations (you may also refer to the picture taken in Step3). Do not overtighten.

NOTICE! a) The following illustration is for reference, which may be different from the wiring for your application. b) The thermostat only works with low-voltage wires (AC 24 V), so it is very important to make sure that the thermostat is not connected to high-voltage wires.

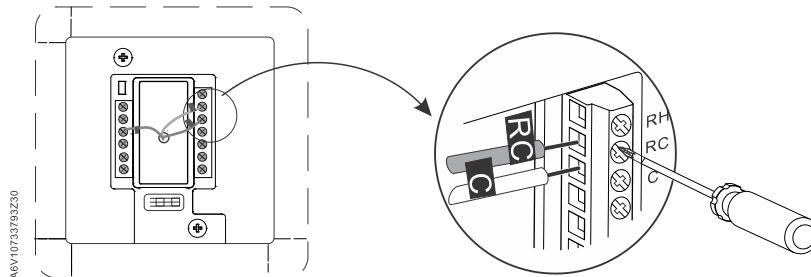

8. Attach the front module horizontally, making sure that each side of the front module fully aligns with that of the power unit, and then press the corners following the order described in the following illustration until you hear a click sound. Note that you need to discharge the static electricity on your body before mounting the front module. For example, touching the wall could help on Electro-Static discharge (ESD).

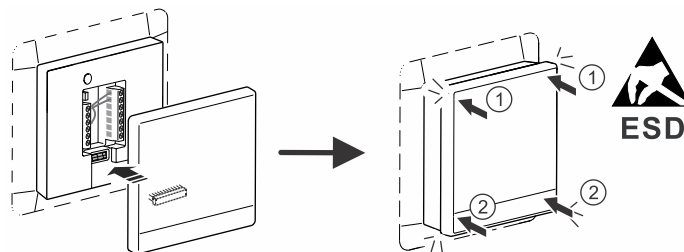

9. Switch on power to the heating/cooling system. The thermostat should be powered up as well.

Wiring

See [Mounting instructions](#) for more information.



- Observe local codes regarding wire type, overcurrent protection and ground.
- For HVAC systems with a single transformer, the RH-RC jumper must remain in place. If separate transformers are used for heating and cooling systems, remove the RH-RC jumper.
- 24 Vac supply line must have a circuit breaker with a rated current of no more than 4 A. The total current rating should not exceed 3.3 A. For 24 Vac US installations, use Class 2 transformers.
- Disconnect from power supply before removing the front module and the mounting plate.

3 Setup wizard

When the thermostat is powered up for the first time, a setup wizard displays to guide you through the following procedures:

- Setting a display language
- Setting an administrator password
- Setting up a network connection and choosing the network connection type
- Selecting an equipment type and setting up the details
- Configuring date
- Specifying a name to the location where the thermostat is installed

For more details, see the [Quick guide](#).

4 Presence detection

4.1 Presence detection using the built-in PIR sensor

By using a built-in presence detection sensor (also called PIR (Passive infrared detector) sensor), the thermostat can detect the space occupancy and then do the following:

- Activate the idle display. When no operations are performed, the thermostat detects whether someone is in the room or not. If it detects someone is in the room, it displays information such as room temperature, room air quality and relative room humidity. If it detects no one is in the room, it turns off the screen.
- Change the operating mode from **Unoccupied** to **Comfort**. If an unoccupied room is detected to be occupied when a scheduled **Unoccupied** mode is running, the thermostat switches to **Comfort** automatically until the next scheduled mode starts. However, you can decide not to switch to **Comfort** if you want. For more information about operating modes, see the [User guide](#).

Sensor position

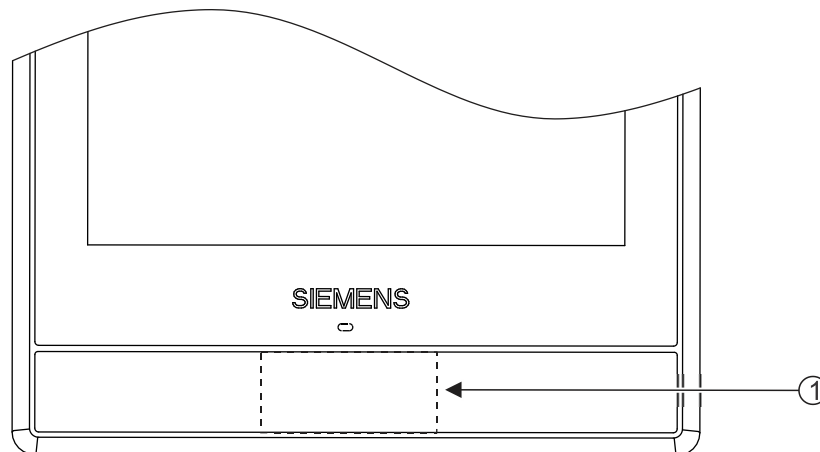



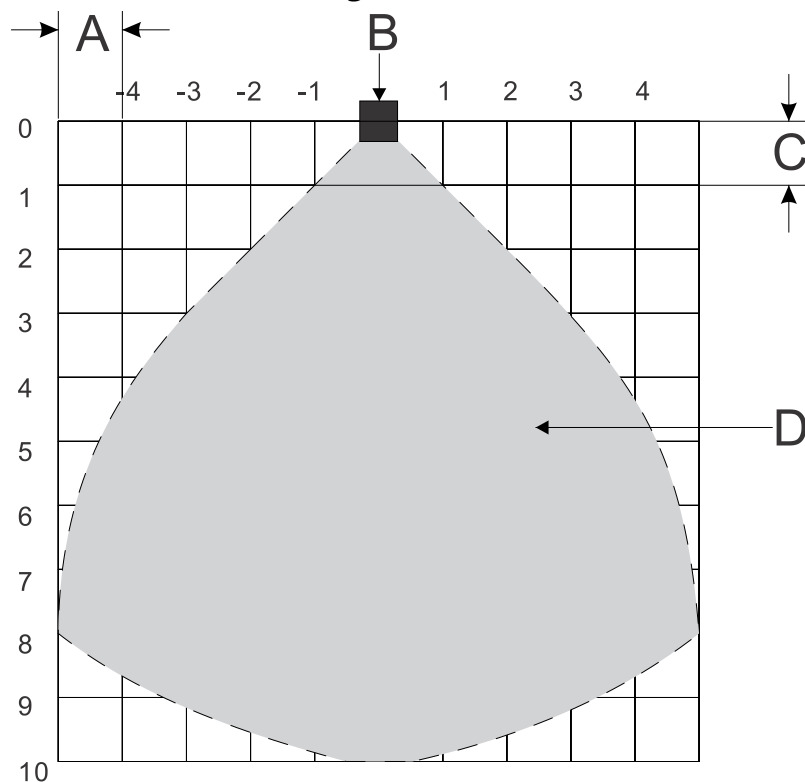



- | | |
|---|--|
| 1 | The location of the PIR sensor. It is a black area if seen from the front of the front module. |
|---|--|

Sensor detection range

A	The width of each cell. It is 80 cm (31 in).
B	The thermostat.
C	The height of each cell. It is 80 cm (31 in).
D	The area that the PIR sensor can detect.

To disable the switch from Unoccupied to Comfort even if the room is occupied

1. From the Home screen, tap , tap  and then tap .
2. If prompted, enter the administrator password.
3. Tap , tap , and then tap . Scroll down and tap **Room presence detector**.
4. Drag the slider to the left if **Active** is displayed on the screen.

4.2 Approach detection

The thermostat has a built-in approach sensor. It can detect someone approaching the thermostat. If activity is sensed within 10 cm, it will switch from its idle screen to the main home screen with full temperature and setpoint display.

Sensor position

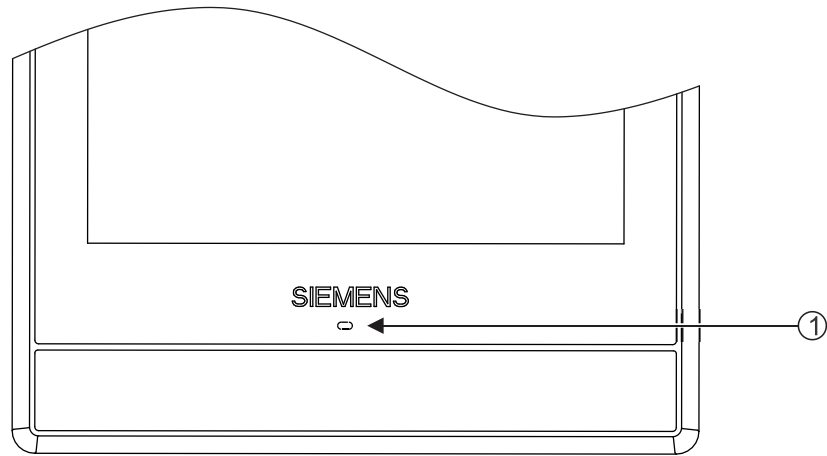

- 1 The location of the approach sensor.





5 Changing system setup

Go to **Advanced Settings** if necessary to reconfigure initial setup options and change some other default system setup options as desired.

Changing basic configurations

Changing the basic configurations of the thermostat is to select either **Conventional** or **Heat pump** and adjust the basic heating/cooling settings for the selected equipment type.

To change the basic configurations

1. From the Home screen, tap , tap < and then tap .
2. If prompted, enter the administrator password.
3. Tap  and then tap .
4. Tap **OK** to stop all of the thermostat's applications. The thermostat restarts.
5. After the restart is completed, tap **Equipment** and then tap **Adapt**.
6. Select the equipment type that you want to change settings for.
7. If **Conventional** is selected, change the heating/cooling stage value or fan operation condition as desired (you can decide if the fan operates when heating is energized).
8. If **Heat pump** is selected, change the following as needed:
 - Heating/cooling stage value.
 - Reversing valve's operating condition. You can decide to energize the reversing valve for heating or cooling.
 - Auxiliary heating stage and operation condition. Two auxiliary heating stages are available. Once you've selected one stage, you can decide if the auxiliary heating device is allowed during heat pump operation. Normally, when the heat pump is running, an auxiliary electrical heating system is allowed but an auxiliary gas heating system is not.

NOTE: Refer to the following part to configure some other relevant advanced settings.

Changing extended configurations

By changing extended configurations, you can:

- Change input assignments. Before any reconfigurations or changes to another input, it is strongly recommended corresponding peripheral devices be connected to terminal X1 or X2. The input can be:
 - Room temperature
 - Operating mode switch

The thermostat switches to the **OFF** mode if the input is configured as **Normally open**. For example, if a thermostat in a hotel is configured to **Normally open** for this input, when a hotel guest pulls out the room card, it activates **Normally open**. The thermostat switches to the **OFF** mode. Once the room card is inserted again, the thermostat restarts the previously running mode.

If the X1 or X2 input is assigned as **Operating mode switch** and configured as **Normally open** but physically terminal X1/X2 is not connected with any corresponding peripheral devices, the thermostat may switch to the **OFF** mode in the end and refuse to function normally unless you change to another input.



 - Universal contact

- Outside air temperature
- Room air humidity
- Presence detector
- Condensation monitor. If the thermostat receives an input from a condensation monitor, it will display a notification on the mobile app. The thermostat does not alter operation based on this input.
- Room air quality
- Change input signal types based on the assigned input type. The following signal types are supported:
NOTICE! If the corresponding application hasn't been configured, some inputs may not be selectable.
 - Digital input, normally open or closed
 - 1k Ohm @ 32 F Ni RTD (LG-Ni1000)
 - 1k Ohm Pt. RTD (385a)
 - 1k Ohm Pt RTD (375a)
 - Type 2 Thermistor
 - 0 to 10 V*
- Set sensor evaluation mode if an external sensor is connected to either terminal X1 or X2. You can use either the built-in and external sensors, or the external sensors, for controlling and monitoring. The former is selected by default. However, if no physical external sensors are connected to any control inputs or if the input values are invalid, only the built-in sensors are used instead to provide values for the thermostat. If external sensors are connected and can provide valid values with the built-in sensors, the thermostat reacts differently depending on the type of the external sensor:
 - Displays the average value if it is an external temperature or humidity sensor.
 - Takes the higher value if it is an external VOC sensor.
 - Enable presence detection related functions no matter whether it is the external or the built-in presence detection sensor detects that someone is in the room.
- If the selected equipment type is **Heat pump**, decide if the heat pump shall be switched off below a certain outside air temperature. If yes, specify the default temperature value. Note that an external outside air temperature sensor is required to be connected with the thermostat to get the outside temperature.
- If the selected equipment type is **Heat pump** and auxiliary heating is allowed to operate when the heat pump is running, you can decide if the auxiliary heating device shall be switched off above a certain outside air temperature. If yes, specify the default temperature value. Note that an external outside air temperature sensor is required to be connected with the thermostat to get the outside temperature.
- Configure the output as a humidifier, humidifier free-standing, dehumidifier, dehumidifier free-standing or an outside air damper.
- Activate or deactivate dehumidification. If the output is not configured as a dehumidifier or dehumidifier free-standing, the thermostat takes use of the heat pump or cooling system to dehumidify the space. However, the heat pump turns off cooling (if cooling operation is running) whenever there is a dehumidification command.
- Activate or deactivate ventilation. Only when the output is configured as an outside air damper can the ventilation function be activated. The ventilation function is mainly used to improve the room air quality when the room is

detected to have worse air quality than the configured room air quality setpoint under the **Optimization** page.

*) If 0 to 10 V is selected as the signal type, a DC 0 to 10 V active sensor must be connected with the thermostat. Otherwise, the calculated value may not be accurate.



To change the extended configurations

1. On the **Advanced Settings** page, tap .
2. If prompted, enter the administrator password.
3. Tap  and then tap .
4. Tap **OK** to stop all the thermostat's applications. The thermostat restarts.
5. After the restart is completed, tap **I/O** and then tap **Adapt**.
6. Change the settings as desired.

Resetting the thermostat

You can reset the thermostat to its original factory settings. However, all user data will be erased after the factory resetting.

To perform a factory reset

1. On the **Advanced Settings** page, tap .
2. If prompted, enter the administrator password.
3. Tap  > .
4. Tap **OK** to stop all of the thermostat's applications. The thermostat restarts.
5. After the restart is completed, tap **Factory Reset**.
6. Tap **Reset**. The thermostat is reset and restarted.

NOTE: After the thermostat is restarted, the setup wizard appears for easy commissioning. Refer to the [Quick guide](#) for the detailed setup information.

6 Managing application settings

NOTE:

- Parameter availability depends on your selected application for the thermostat.
- Numbers marked in the following tables are only for easy readability in this document. They don't represent the parameter numbers in the local thermostat.

Multi-functional inputs

No.	Application settings	Descriptions	Factory settings	Range	Dependencies
1.	X1 room temp. ref. at 0V	Calibrates thermostat to low end of temperature sensor signal (for example, 0V = 32°F)	32°F (0°C)	-58...176°F (-50...80 °C)	A DC 0 to 10V external room temperature sensor must be connected with the thermostat using terminal X1.
2.	X1 room temp. ref. at 10V	Calibrates thermostat to high end of temperature sensor signal (for example, 10V = 122°F)	122°F (50°C)	-58...176°F (-50...80 °C)	
3.	X2 room temp. ref. at 0V	Calibrates thermostat to low end of temperature sensor signal (for example, 0V = 32°F)	32°F (0°C)	-58...176°F (-50...80°C)	A DC 0 to 10V external room temperature sensor must be connected with the thermostat using terminal X2.
4.	X2 room temp. ref. at 10V	Calibrates thermostat to high end of temperature sensor signal (for example, 10V = 122°F)	122°F (50°C)	-58...176°F (-50...80 C)	
5.	Outside temp. ref. at 0V	Calibrates thermostat to low end of temperature sensor signal (for example, 0V = -58°F)	-58°F (-50°C)	-58...176°F (-50...80°C)	A DC 0 to 10V external outside air temperature sensor must be connected.
6.	Outside temp. ref. at 10V	Calibrates thermostat to high end of temperature sensor signal (for example, 10V = 176°F)	176°F (80°C)	-58...176°F (-50...80°C)	

Heating setpoints

No.	Application settings	Descriptions	Factory settings	Range	Dependencies
7.	Comfort heating setpoint	Scheduled heating setpoint when space is occupied. This setpoint must be higher than that for Protection .	70°F (21°C)	32...122°F (0...50°C)	N/A
8.	Economy heating setpoint	Scheduled heating setpoint during transition from Unoccupied to Comfort . This setpoint must be higher than that for Protection .	66°F (19°C)	32...122°F (0...50°C)	N/A
9.	Unoccupied heating setpoint	Scheduled heating setpoint when space is unoccupied. This setpoint must be higher than that for Protection .	59°F (15°C)	32...122°F (0...50°C)	N/A
10.	Protection heating setpoint	Heating setpoint if the operating mode is OFF and Protection is enabled.	45°F (7°C)	32...122°F (0...50°C)	This setpoint is valid only if the default Protection option is selected for Application setting No. 57.
11.	Max. heating setpoint	Maximum allowable heating setpoint.	95°F (35°C)	32...122°F (0...50°C)	

Cooling setpoints

No.	Application settings	Descriptions	Factory settings	Range	Dependencies
12.	Comfort cooling setpoint	Scheduled cooling setpoint when space is occupied. This setpoint must be higher than all the heating setpoints and lower than the cooling setpoint for Protection .	75°F (24°C)	32...122 F (0...50°C)	N/A
13.	Economy cooling setpoint	Scheduled cooling setpoint during transition from Unoccupied to Comfort . This setpoint must be higher than all the heating setpoints and lower than the cooling setpoint for Protection .	77°F (25°C)	32...122 F (0...50°C)	N/A
14.	Unoccupied cooling setpoint	Scheduled cooling setpoint when space is unoccupied. This setpoint must be higher than all the heating setpoints and lower than the cooling setpoint for Protection .	86°F (30°C)	32...122 F (0...50°C)	N/A
15.	Protection cooling setpoint	Cooling setpoint if the operating mode is OFF and Protection is enabled. This setpoint must be higher than all the heating setpoints.	95°F (35°C)	32...122 F (0...50°C)	This setpoint is valid only if the default Protection option is selected for Application setting No. 57.
16.	Min. cooling setpoint cool.	Minimum allowable cooling setpoint.	45°F (7 °C)	32...122 F (0...50°C)	The cooling protection setpoint is valid only if the default Protection option is selected for Application setting No. 57.

Humidity setpoints

No.	Application settings	Descriptions	Factory settings	Range	Dependencies
17.	Comfort humidity setpoint	Scheduled humidification setpoint when space is occupied. This setpoint must be higher than that for Protection .	40%RH	0...100%RH	Displays only if the output is configured as Humidifier (no fan) .
18.	Economy humidity setpoint	Scheduled humidification setpoint during transition from Unoccupied to Comfort . This setpoint must be higher than that for Protection .	40%RH	0...100%RH	
19.	Unoccupied humidity setpoint	Scheduled humidification setpoint when space is unoccupied.	30%RH	0...100%RH	
20.	Protection humidity setpoint	The humidification setpoint if the operating mode is OFF and Protection is enabled. This setpoint must be lower than all the dehumidification setpoints..	30%RH	0...100%RH	This setting displays only if the output is configured as Humidifier (no fan) or Humidifier (fan) min. ON time . This setpoint is valid only if the default Protection option is selected for Application setting No. 57.

NOTE: Humidification control works with a PID algorithm. The algorithm continuously monitors the difference between the humidity setpoint for humidification and the measured relative air humidity in the room and switches the humidifier ON and OFF automatically to keep the humidity above the setpoint. It is not possible to switch the humidifier ON and OFF manually. Changing the setpoint will affect the humidification control to verify the functionality.

Dehumidification setpoints

No.	Application settings	Descriptions	Factory settings	Range	Dependencies
21.	Comfort dehum. setpoint	Scheduled dehumidification setpoint when space is occupied. This setpoint must be lower than that for Protection .	60%RH	0...100%RH	Displays only if the output is configured as Dehumidifier (no fan) or Dehumidifier (fan) .
22.	Economy dehum. setpoint	Scheduled dehumidification setpoint during transition from Unoccupied to Comfort . This setpoint must be lower than that for Protection .	60%RH	0...100%RH	
23.	Unoccupied dehum. setpoint	Scheduled dehumidification setpoint when space is unoccupied.	70%RH	0...100%RH	
24.	Protection dehum. setpoint	The dehumidification setpoint if the operating mode is OFF and Protection is enabled. This setpoint must be higher than all the humidification setpoints for Protection .	70%RH	0...100%RH	This setting displays only if the output is configured as Dehumidifier (no fan) . This setpoint is valid only if the default Protection option is selected for Application setting No. 57.
25.	Max.deviation heating f.dehumidification	Dehumidification is only allowed when the temperature difference between the current setpoint and the room temperature is within the set value.	3 K	0...10 K	The dehumidification function must be enabled during the configuration of input and output.

NOTE: Dehumidification control works with a PID algorithm. The algorithm continuously monitors the difference between the humidity setpoint for dehumidification and the measured relative air humidity in the room and switches the dehumidifier ON and OFF automatically to keep the room humidity below the setpoint. It is not possible to switch the dehumidifier ON and OFF

manually. Changing the setpoint will affect the dehumidification control to verify the functionality.

Room air quality setpoints

No.	Application settings	Descriptions	Factory settings	Range	Dependencies
26.	Comfort air quality setpoint	Scheduled air quality setpoint when space is occupied. This setpoint must be lower than that for Protection .	900 ppm	0...2000 ppm	Displays only if the output is configured as an outside air damper in section Changing system setup [→ 14].
27.	Economy air quality setpoint	Scheduled air quality setpoint during transition from Unoccupied to Comfort . This setpoint must be lower than that for Protection .	1100 ppm	0...2000 ppm	
28.	Unoccupied air quality setpoint	Scheduled air quality setpoint when space is unoccupied.	1500 ppm	0...2000 ppm	
29.	Protection air quality setpoint	The air quality setpoint if the operating mode is OFF and Protection is enabled.	1500 ppm	0...2000 ppm	

Functions

No.	Application settings	Descriptions	Factory settings	Range	Dependencies
30.	Humidity control in heating only	Humidification allowed only when heating system is energized.	No	N/A	The output must be configured as a humidifier.
31.	Free cooling	Enables free cooling by opening the outside air damper.	No	N/A	The output must be configured as an outside air damper.
32.	Room presence detector	The thermostat switches from Unoccupied to Comfort when occupancy is detected.	Active	N/A	N/A

Temperature offsets

No.	Application settings	Descriptions	Factory settings	Range	Dependencies
33.	Built-in temp. sensor adj.	Temperature offset value for the built-in room temperature sensor.	0 K	-5...5 K	Valid only if the built-in temperature sensor is used to measure the temperature.
34.	X1 temp. sensor adj.	Temperature offset value for the X1 temperature sensor.	0 K	-5...5 K	Valid only if an external room temperature sensor is connected using X1.
35.	X2 temp. sensor adj.	Temperature offset value for the X2 temperature sensor.	0 K	-5...5 K	Valid only if an external room temperature sensor is connected using X2.

Switchover time adjustment

No.	Application settings	Descriptions	Factory settings	Range	Dependencies
36.	Electric heating coil fan overrun	Fan will remain energized for this amount of time after heating is de-energized.	30 s	0...600 s	The thermostat must be set to activate fan in heating mode. If heat pump, at least one stage of aux. heat must be enabled.
37.	Damper min. ON time	Minimum time that outside air damper will remain energized.	3 min	0...60 min	
38.	Damper min. OFF time	The minimum time between outside air damper cycles.	3 min	0...60 min	
39.	Fan min. ON time	Minimum run time for fan when controlled by thermostat.	3 min	0...60 min	A fan operation condition must be set during equipment type selection.
40.	Fan min. OFF time	Minimum off time for fan when controlled by thermostat.	3 min	0...60 min	





No.	Application settings	Descriptions	Factory settings	Range	Dependencies
41.	Changeover delay for heating/cooling	The minimum off time before switching between heating and cooling.	300 s	30...600 s	Heat pump must be selected as the equipment type.
42.	HP compressor min. ON time	Minimum run time for compressor(s) in heat pump systems.	3 min	0...60 min	
43.	HP compressor min. OFF time	Minimum off time for compressor(s) in heat pump systems.	3 min	0...60 min	
44.	Heating min. ON time	The minimum run time for the heating system.	5 min	3...15 min	
45.	Heating min. OFF time	The minimum off time for the heating system.	5 min	3...15 min	
46.	Cooling min. ON time	The minimum run time for the cooling system	5 min	3...15 min	
47.	Cooling min. OFF time	The minimum off time for the cooling system	5 min	3...15 min	
48.	Humidifier (fan) min. ON time	The minimum run time for the humidifier	3 min	0...60 min	The output must have been configured as a humidifier.
49.	Humidifier (fan) min. OFF time	The minimum off time for the humidifier	3 min	0...60 min	
50.	Dehum. (fan) min. ON time	The minimum run time for the dehumidifier	3 min	0...60 min	The output must have been configured as a dehumidifier.
51.	Dehum. (fan) min. OFF time	The minimum off time for the dehumidifier	3 min	0...60 min	

No.	Application settings	Descriptions	Factory settings	Range	Dependencies
52.	Humidify (no fan) min. ON time	The minimum run time of a standalone humidifier. This minimum limitation protects the humidifier from short cycling.	3 min	0...60 min	The output must have been configured as Humidifier (no fan) in Changing system setup [→ 14].
53.	Humidify (no fan) min. OFF time	The minimum OFF time of a standalone humidifier. This minimum limitation protects the humidifier from short cycling.	3 min	0...60 min	
54.	Dehum. (no fan) min. ON time	The minimum run time of a standalone dehumidifier. This minimum limitation protects the dehumidifier from short cycling.	3 min	0...60 min	The output must have been configured as Dehumidifier (no fan) in Changing system setup [→ 14].
55.	Dehum. (no fan) min. OFF time	The minimum OFF time of a standalone dehumidifier. This minimum limitation protects the dehumidifier from short cycling.	3 min	0...60 min	

Other settings

No.	Application settings	Descriptions	Factory settings	Range	Dependencies
56.	Min.diff.room temp./outs.air temp.f.cool	Free cooling will not be allowed if the difference between room temperature and outdoor temperature is less than this value.	0 K	0...20 K	N/A
57.	Off/protection configuration	Configures whether the thermostat goes to the protection mode or completely turns off in OFF mode.	Protection	Off Protection	N/A
58.	Filter change interval	A specified time interval of replacing the filter. Pre-warning countdown information will remind you of replacing the filter before the time is due.	4380 h	1...8760 h	A fan operation condition must be set during equipment type selection.

To manage application settings

1. From the Home screen, tap , then tap < and .
2. If prompted, enter the administrator password.
3. Tap  > , and then scroll to the specific setting that you want to turn on/off or change to a desired value.
4. Tap to change the setting as desired.

7 Disassembly

The thermostat is designed for maintenance-free operations. Disassembling should only be done after the power supply is off and is only limited to the licensed installers only for disposal purpose. Siemens doesn't guarantee the user's safety if the disassembly process is managed by any unlicensed installers.

Disassembly

1. Turn off the power supply and then use a screw driver to pry the front module off from the hole at the top of the thermostat.

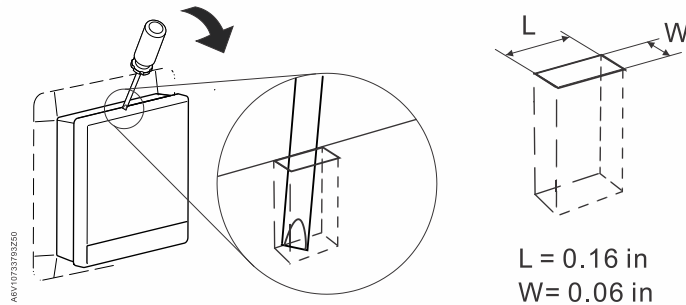

2. If needed, disconnect the cables or detach the rear module by unscrewing the screws anticlockwise. Or, if there is decoration frame, detach it as well by unscrewing the screws.

NOTE: To prevent uncontrolled heating/cooling, remove power from the thermostat before removing the front module.

8 Appendices

8.1 Technical specifications

Please refer to the [datasheet of this product](#) for technical specification details.

8.2 Cyber security disclaimer

Siemens provides a portfolio of products, solutions, systems and services that includes security functions that support the secure operation of plants, systems, machines and networks. In the field of Building Technologies, this includes building automation and control, fire safety, security management as well as physical security systems.

In order to protect plants, systems, machines and networks against cyber threats, it is necessary to implement – and continuously maintain – a holistic, state-of-the-art security concept. Siemens' portfolio only forms one element of such a concept.

You are responsible for preventing unauthorized access to your plants, systems, machines and networks which should only be connected to an enterprise network or the internet if and to the extent such a connection is necessary and only when appropriate security measures (e.g. firewalls and/or network segmentation) are in place. Additionally, Siemens' guidance on appropriate security measures should be taken into account. For additional information, please contact your Siemens sales representative or visit

<https://www.siemens.com/global/en/home/company/topic-areas/future-of-manufacturing/industrial-security.html>.

Siemens' portfolio undergoes continuous development to make it more secure. Siemens strongly recommends that updates are applied as soon as they are available and that the latest versions are used. Use of versions that are no longer supported, and failure to apply the latest updates may increase your exposure to cyber threats. Siemens strongly recommends to comply with security advisories on the latest security threats, patches and other related measures, published, among others, under

<https://www.siemens.com/cert/en/cert-security-advisories.htm>.

8.3 Regulatory information

8.3.1 ISED Regulations (Canada)

This device complies with Industry Canada license-exempt RSS standard(s).

Operation is subject to the following two conditions: (1) this device may not cause interference,

and (2) this device must accept any interference, including interference that may cause undesired operation of the device.

Le présent appareil est conforme aux CNR d'Industrie Canada applicables aux appareils radio

exempts de licence. L'exploitation est autorisée aux deux conditions suivantes :

(1) l'appareil ne

doit pas produire de brouillage, et (2) l'utilisateur de l'appareil doit accepter tout brouillage

radioelectrique subi, meme si le brouillage est susceptible d'en compromettre le fonctionnement.

8.3.2 FCC Regulations (USA)

	<p>⚠ WARNING</p>
	<p>Modification of this device to receive cellular radio telephone service signals is prohibited under FCC rules and federal law.</p> <p>This equipment has been tested and found to comply with the limits for a Class B digital device, pursuant to part 15 of the FCC Rules. These limits are designed to provide reasonable protection against harmful interference in a residential installation. This equipment generates, uses and can radiate radio frequency energy and, if not installed and used in accordance with the instructions, may cause harmful interference to radio communications. However, there is no guarantee that interference will not occur in a particular installation. If this equipment does cause harmful interference to radio or television reception, which can be determined by turning the equipment off and on, the user is encouraged to try to correct the interference by one or more of the following measures:</p> <ul style="list-style-type: none"> Reorient or relocate the receiving antenna. Increase the separation between the equipment and receiver. Connect the equipment into an outlet on a circuit different from that to which the receiver is connected. Consult the dealer or an experienced radio/TV technician for help. <p>This equipment complies with FCC radiation exposure limits set forth for an uncontrolled environment. This equipment should be installed and operated with minimum distance of 20cm between the radiator & your body.</p> <p>Changes or modifications not expressly approved by the party responsible for compliance could void the user's authority to operate the equipment.</p>

Statement

This device complies with part 15 of the FCC Rules. Operation is subject to the following two conditions: (1) This device may not cause harmful interference, and (2) this device must accept any interference received, including interference that may cause undesired operation.

8.4 EULA

The software included in this product is licensed for use subject to the Siemens end-user license agreement (EULA) posted at www.siemens.com/smart-thermostat or this software identified by product model or part number on the website. The open source software (OSS) information about the software can also be found from the same website.

Issued by
Siemens Industry, Inc.
Smart Infrastructure
1000 Deerfield Pkwy
Buffalo Grove IL 60089
+1 847-215-1000

© Siemens Industry, Inc., 2019
Technical specifications and availability subject to change without notice.