

## Commercial Fan Coil Room Thermostat

RDG110U and RDG160TU



**Siemens RDG110U and RDG160TU are very versatile wall-mounted thermostats for low voltage, stand-alone applications such as in hospitality, dormitory or light commercial applications.**

- 7-day program with 8 programmable timers to switch over between Comfort and Economy modes (RDG160TU).
- Multi-functional inputs can be configured for keycard input, window contacts or external sensors.
- Select from various control strategies including Comfort, Energy Saving, or Freeze Protection.
- Backlit display with intuitive layout simplifies user interaction during commissioning and daily operation.
- Siemens offers a broad selection of sensors and actuators that comprise cost-efficient application bundles that are compatible with the RDG110U and RDG160TU.

## Features

- Room temperature control using built-in temperature sensor or external room/return air temperature sensor
- 2 multi-functional inputs, configurable for:
  - Operating mode switchover contact (keycard, window contact, and so on)
  - Sensor for automatic heating/cooling mode changeover
  - External room temperature or return air temperature sensor
  - Supply air temperature sensor (RDG160TU)
  - Dew point sensor
  - Electric heater enable
  - Fault sensing
- 1 digital input, configurable for:
  - Operating mode switchover contact (keycard, window contact, and so on)
  - Sensor for automatic heating/cooling mode changeover
  - Dew point switch
  - Electric heater enable
  - Fault sensing
- Configurable relay function (RDG160TU)
  - Disables external equipment during Protection mode
  - Enables external equipment (for example, pump) during H/C demand
  - Output H/C sequence
- Automatic or manual heating and cooling mode changeover
- SPDT relays for valves, and SPST relays for 1- to 3-speed fans (RDG110U).
- Modulating or digital outputs for modulating valves, ECM fans, or 1- to 3-speed fans (RDG160TU).
- Purge function when used with 2-port valve in 2-pipe H/C changeover system
- Simple application configuration using DIP switches
- Minimum and maximum supply air temperature limits (RDG160TU)
- Floor heating temperature limit
- Easy operation mode selection with interactive controls
- Filter reminder

## Applications

Type	
<b>Fan Coil Unit Applications</b>	2-pipe 2-pipe and electric heater 2-pipe and radiator 2-pipe/2-stage 4-pipe
<b>Chilled/Heated Ceiling Applications</b>	Chilled/heated ceiling Chilled/heated ceiling and electric heater Chilled/heated ceiling and radiator/floor heating 4-stage chilled/heated ceiling Chilled ceiling and radiator
<b>DX Applications</b>	DX heat or cool DX heat or with electric heat DX heat and cool 2-stage heat or cool

## Ordering Information

Part Number	Description
RDG110U	24V Wall-mounted Thermostat Fan Coil Unit and Heat Pump
RDG160TU	24V Wall-mounted Thermostat Fan Coil Unit, 3-speed/ECM Fan

## Product documentation

Topic	Title	Document Number
Mounting Instructions	RDG160TU	M3183.2
Mounting Instructions	RDG110U	CB1M3183.1
Basic Documentation (Engineering Manual)	Room Thermostats with LCD for Wall Mounting RDG100, RDG100T, RDG110, RDG110U, RDG160T, RDG160TU, RDG100T/H	CE1P3181en
Data Sheet	Wall-mounted room thermostats with LCD, RDG1...	CE1N3181en
Operating Instructions	RDG100, RDG110, RDG110U	CB1B3181en
Operating Instructions	RDG100T, RDG160T, RDG160TU	CB1B3181.5en

## Technical data

Power supply	
Operating voltage	24 Vac/24 Vdc Class 2
Frequency	50/60 Hz.
Power consumption including connected field devices	Max. 2 VA

Multi-functional inputs	
X1-M/X2-M Temperature sensor input Type	NTC 3K $\Omega$ at 77°F (25°C) (Recommended temperature sensor: QAH11.1)
Temperature range	32°F to 120°F (0°C to 49°C)
Cable length	Maximum 262 feet (80m)
Digital input Operating action Contact sensing	Selectable (NO/NC) DC 0 to 5V, maximum 5 mA
D1-GND Operating action Contact sensing	Selectable (NO/NC) DC 6 to 15V, 3 to 6 mA
Function input	External temperature sensor, changeover sensor, mode switch contact, dew point contact, electric heater enable, fault contact

Outputs	
<b>RDG110U</b> Fan control Q1, Q2, Q3-G0 Current min., max. resistive or inductive	24 Vac AC 5 mA to 5A (4A)
Control output Y11-G0/Y21-G0	24 Vac AC 5 mA to 5A (3A)
<b>RDG160TU</b> Q1/Q2/Q3/G-G0 (relay) Use as 3-speed fan control Rating min., max. resistive or Inductive	24 Vac Class 2 5 mA to 5A (4A)
Use as actuator control (Q1, Q2) Q1 rating min., max. resistive or inductive Q2 rating min., max. resistive or inductive Max. total load current Q1 + Q2 + Q3	5 mA to 1A 5 mA to 5A (4A) 5A
Use as external load control (Q1, Q2, Q3) Rating min., max. resistive or inductive each	5 mA to 1A
ECM Fan Control Y50 - G0 max. Actuator Control Y10-G0/Y20-G0 (G)	DC 0 to 10V +/- 5 mA DC 0 to 10V +/- 1 mA

Operational data	
Switching differential, adjustable Heating mode	4°F (2°C) (1°F to 12°F [0.5°C to 6°C])
Cooling mode	2°F (1°C) (1°F to 12°F [0.5°C to 6°C])
Setpoint setting and range Comfort mode	70°F (21°C) (41°F to 104°F [5°C to 40°C])
Energy Saving mode	59°F (15°C) or 86°F (30°C) (OFF, 41°F to 104°F [5°C to 40°C])
Protection	46°F (8°C) (OFF, 41°F to 104°F [5°C to 40°C])
Multi-functional inputs X1/X2/D1 Input X1 Input X2 Input D1	Selectable External temperature sensor Changeover sensor Operating mode switchover
Built-in room temperature sensor Measuring range Accuracy at 77°F (25°C) Temperature calibration range	32°F to 120°F (0°C to 49°C) < ± 1°F (0.5°C) ± 6°F (3°C)
Settings and display resolution Setpoints Current temperature value displayed	1°F (0.5°C) 1°F (0.5°C)

Environmental	
Operation Climatic conditions Temperature Humidity	Class 3K5 32°F to 122°F (0°C to 50°C) < 95% rh
Transport Climatic conditions Temperature Humidity Mechanical conditions	Class 2K3 -13°F to 158°F (-25°C to 70°C) < 95% rh Class 2M2
Storage Climatic conditions Temperature	Class 1K3 -13°F to 158°F (-25°C to 70°C)

Environmental	
Humidity	< 95% rh
Standards	
EU Conformity (CE) RCM Conformity UL Listing cUL Federal Communications Commission  Safety class Degree of protection housing Pollution class	EMC Directive  UL 916 PAZX CSA-C22.2 No. 205 PAZX7 Complies with the limits for a Class B digital device, pursuant to Part 15 of the FCC rules.  III as per EN 60529 IP30 as per EN 60529 Normal
Environmental compatibility	Declaration CE1E3181 contains data on environmentally compatible product design and assessments (RoHS compliance, materials composition, packaging, environmental benefit, disposal).
General Connection terminals  Housing front color Weight	1 × 14 gauge (1 × 0.4 through 2.5 mm <sup>2</sup> ) or 2 × 16 gauge (2 × 0.4 through 1.5 mm <sup>2</sup> )  RAL 9003 white 0.77 lb (0.350 kg)

## Dimensions

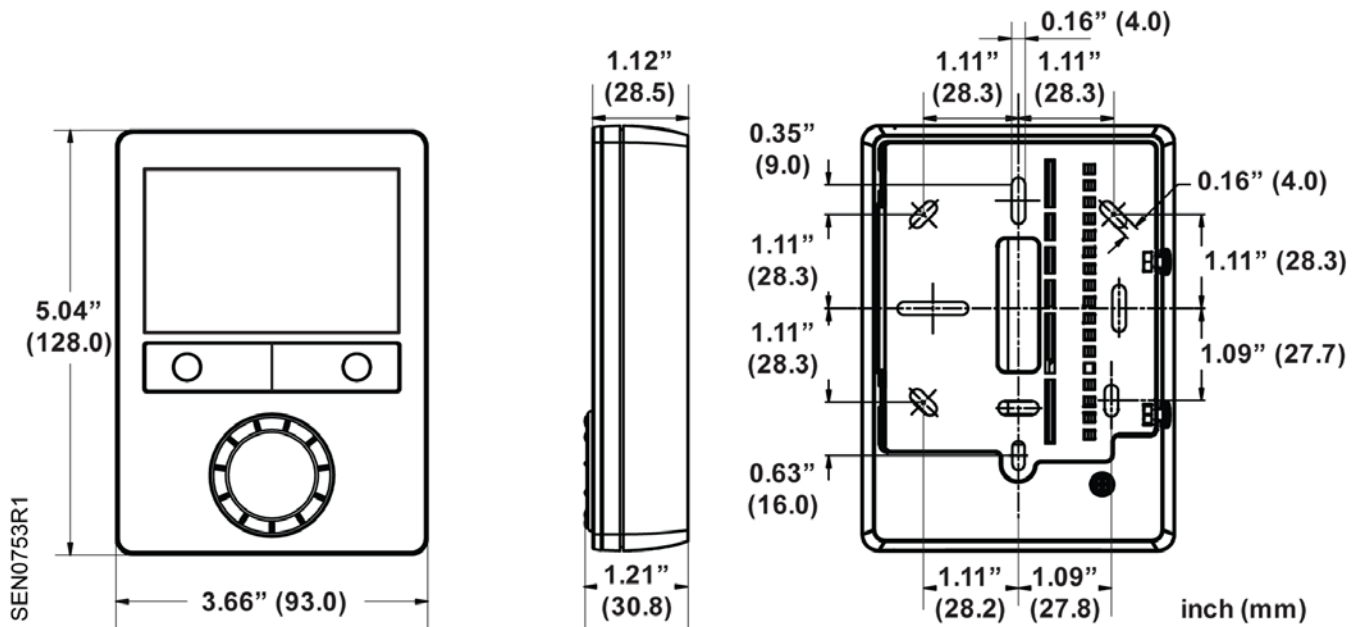

Issued by  
Siemens Industry, Inc.  
Building Technologies Division  
1000 Deerfield Pkwy  
Buffalo Grove IL 60089  
Tel. +1 847-215-1000

© Siemens Industry, Inc., 2015  
Technical specifications and availability subject to change without notice.