

Commercial VAV Thermostat

RDG400



Siemens RDG400 is a versatile Single Duct VAV Thermostat Controller for low voltage stand-alone applications such as in hospitality, dormitory or light commercial applications.

- Multi-functional inputs can be configured for keycard input, window contacts or external sensors.
- Select from various control strategies including Comfort, Energy Saving, or Freeze Protection.
- Backlit display with intuitive layout simplifies user interaction during commissioning and daily operation.
- Siemens offers a broad selection of sensors and actuators that comprise cost-efficient application bundles that are compatible with the RDG400.

Features

- Room temperature control using built-in temperature sensor or external room temperature/return air temperature sensor
- Three multi-functional inputs, configurable for:
 - Operating mode switchover contact (keycard, window contact, and so on)
 - Sensor for automatic heating/cooling mode changeover
 - External room temperature or return air temperature sensor
 - Dew point sensor
 - Fault sensing
- Automatic or manual heating and cooling mode changeover
- Supports electric heater
- Simple application configuration using DIP switches
- Minimum and maximum setpoint limitation
- Floor heating temperature limit
- Easy operation mode selection with intuitive controls
- Button lock (automatic or manual)

Applications

Type	Application
Single-duct	DC 0 to 10V damper actuator 3-position damper actuator
Single-duct with auxiliary heater	DC 0 to 10V damper actuator and ON/OFF, PWM or 3-position auxiliary heater 3-position damper actuator and DC 0 to 10V auxiliary heater
Single-duct and radiator/floor heating	DC 0 to 10V damper actuator and ON/OFF, PWM or 3-position radiator 3-position damper actuator and DC 0 to 10V radiator
Single-duct heating and cooling coil	DC 0 to 10V damper actuator and ON/OFF, PWM or 3-position heating and cooling 3-position damper actuator and DC 0 to 10V heating and cooling

Ordering Information

Part Number	Description
RDG400	24V Thermostat VAV/CAV

Product documentation

Topic	Title	Document Number
Mounting Instructions	RDG400 VAV/CAV Thermostat	M3182
Basic Documentation (Engineering Manual)	Room Thermostat with Display for VAV, RDG400	CE1P3182en
Data Sheet	Wall-mounted Room Thermostat with LCD, RDG 400	CE1N3182en
Operating Instructions	RDG400	CB1B3182.en

Technical data

Power supply	
Operating voltage	24 Vac/24 Vdc Class 2
Frequency	50/60 Hz.
Power consumption including connected field devices	Max. 2 VA

Multi-functional inputs	
X1-M/X2-M Temperature sensor input Type	NTC 3K Ω at 77°F (25°C) (Recommended temperature sensor: QAH11.1)
Digital input Operating action Contact sensing	Selectable (NO/NC) DC 0 to 5V, maximum 5 mA
DI-GND Operating action Contact sensing	Selectable (NO/NC) DC 6 to 15V, 3 to 6 mA
Function input	External temperature sensor, changeover sensor, mode switch contact, dew point contact, electric heater enable, fault contact
Outputs	
Control output Y10-G0 Resolution Current	DC 0 to 10V 39 mV Maximum \pm 1 mA
Control output Y1, Y2-G Rating	24 Vac 15 mA to 1A
Operational data	
Switching differential, adjustable Heating mode Cooling mode	6°F (2°C) (1°F to 12°F [0.5°C to 6°C]) 2°F (1°C) (1°F to 12°F [0.5°C to 6°C])
Setpoint setting and range Comfort mode Energy Saving mode Protection	70°F (21°C) (41°F to 104°F [5°C to 40°C]) 59°F (15°C) or 86°F (30°C) (OFF, 41°F to 104°F [5°C to 40°C]) 46°F (8°C)
Multi-functional inputs X1/X2/D1 Input X1 Input X2 Input D1	Selectable External temperature sensor Changeover sensor Operating mode switchover
Built-in room temperature sensor Measuring range Accuracy at 77°F (25°C) Temperature calibration range	32°F to 120°F (0°C to 49°C) < \pm 1°F (0.5°C) \pm 6°F (3°C)
Settings and display resolution Setpoints Current temperature value displayed	1°F (0.5°C) 1°F (0.5°C)
Environmental	
Operation Climatic conditions Temperature Humidity	Class 3K5 32°F to 122°F (0°C to 50°C) < 95% rh
Transport Climatic conditions Temperature Humidity Mechanical conditions	Class 2K3 -13°F to 158°F (-25°C to 70°C) < 95% rh Class 2M2
Storage Climatic conditions Temperature Humidity	Class 1K3 -13°F to 158°F (-25°C to 70°C) < 95% rh

Standards	
EU Conformity (CE) RCM Conformity UL Listing cUL Federal Communications Commission	EMC Directive UL 916 PAZX CSA-C22.2 No. 205 PAZX7 Complies with the limits for a Class B digital device, pursuant to Part 15 of the FCC rules.
Safety class Degree of protection housing Pollution class	III as per EN 60529 IP30 as per EN 60529 Normal
Environmental compatibility	Declaration CE1E3181 contains data on environmentally compatible product design and assessments (RoHS compliance, materials composition, packaging, environmental benefit, disposal).
General Connection terminals Housing front color Weight	 1 × 14 gauge (1 × 0.4 through 2.5 mm ²) or 2 × 16 gauge (2 × 0.4 through 1.5 mm ²) RAL 9003 white 0.77 lb (0.350 kg)

Dimensions

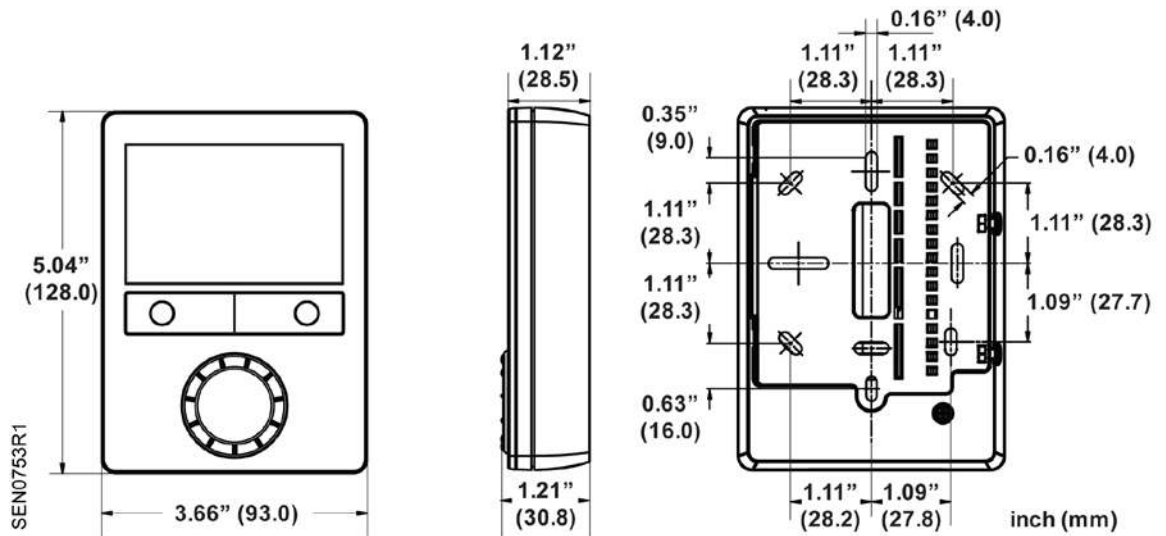

Issued by
Siemens Industry, Inc.
Building Technologies Division
1000 Deerfield Pkwy
Buffalo Grove IL 60089
Tel. +1 847-215-1000

© Siemens Industry, Inc., 2015
Technical specifications and availability subject to change without notice.