

Door Keypad Mounting Kit - Mounting Instructions

1. Introduction

The Door Keypad is used for the same purpose as the standard control keypad. It is installed on the door of a switchgear cabinet.

For the installation, you need the following parts (see picture below):

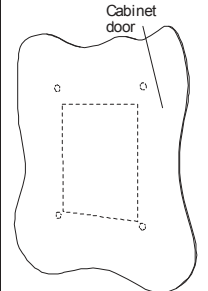
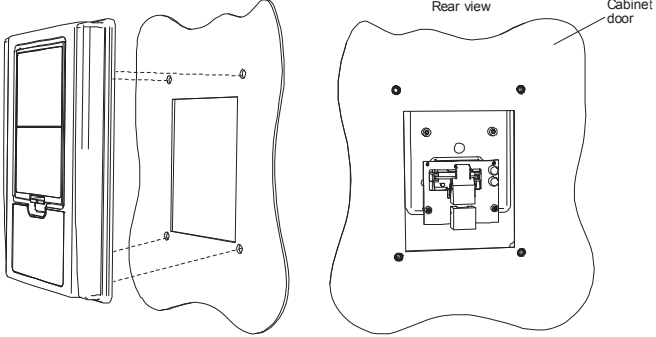
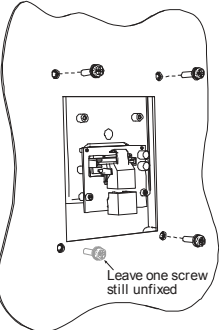

Figure 1. Door keypad mounting kit

1. Screws (4 pcs)
2. Data cable with attached grounding cable
3. Panel adapter kit (packaged). See manual in package for components.
4. Door keypad base

Make sure that you have received all necessary parts!

2. Mounting procedure

1	<p>Make an opening in the cabinet door for the control keypad according to the dimensions in Appendix 1. Make also the holes in the cabinet door for the screws using the dimensions in Appendix 1.</p>	
2	<p>Place the control keypad base (1.) toward the opening so that the screw holes you made in the cabinet door meet the bushings on the backside of the base. See figures below.</p>	
3	<p>Fix the base on the cabinet door by tightening the screws (3.).</p>	

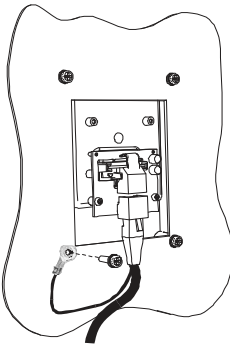
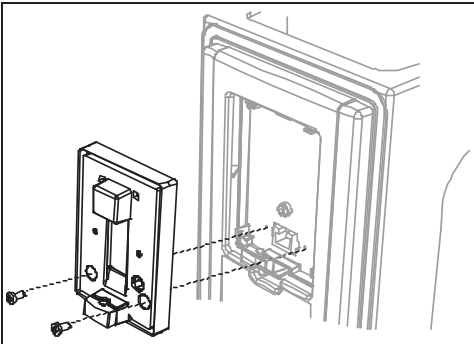
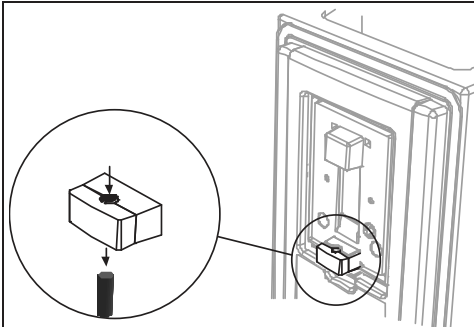
<p style="text-align: center; font-size: 24pt; font-weight: bold;">4</p>	<p>Also fix the grounding cable (2.) against the backside of the cabinet door through one of the screw holes.</p> <p>NOTE: Ensure that a proper contact with the cabinet door is achieved. Remove, if necessary, the paint from the metal surface.</p> <p>Don't forget to place the washers (attached to the screws) between the door and the screws. The tightening torque to be applied is 1.5 Nm (13.27 lbf-in). Connect the data cable (2.) to the terminal of the keypad.</p> 
<p style="text-align: center; font-size: 24pt; font-weight: bold;">5</p>	<p>Fix the transparent cover B of the panel adapter kit (3.) to the keypad base using the two screws provided in the package. Tighten the screws to max. 1 Nm (8.85 lbf-in).</p> 
<p style="text-align: center; font-size: 24pt; font-weight: bold;">6</p>	<p>Detach the foam rubber gasket from the transparent cover and punch out the cylinder-formed piece of foam rubber in order to open way for the cable. The gasket can then be split into two pieces.</p> 

7

Then insert cable and fix the black cover A with the two screws provided. Tighten the screws to max. 1 Nm (8.85 lbf-in).

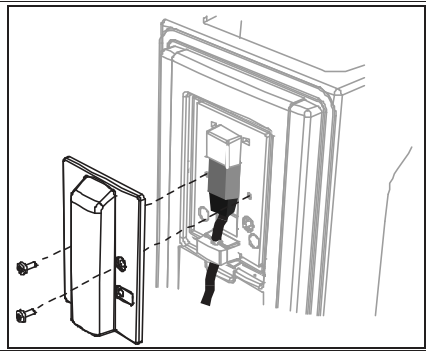

3. APPENDIX

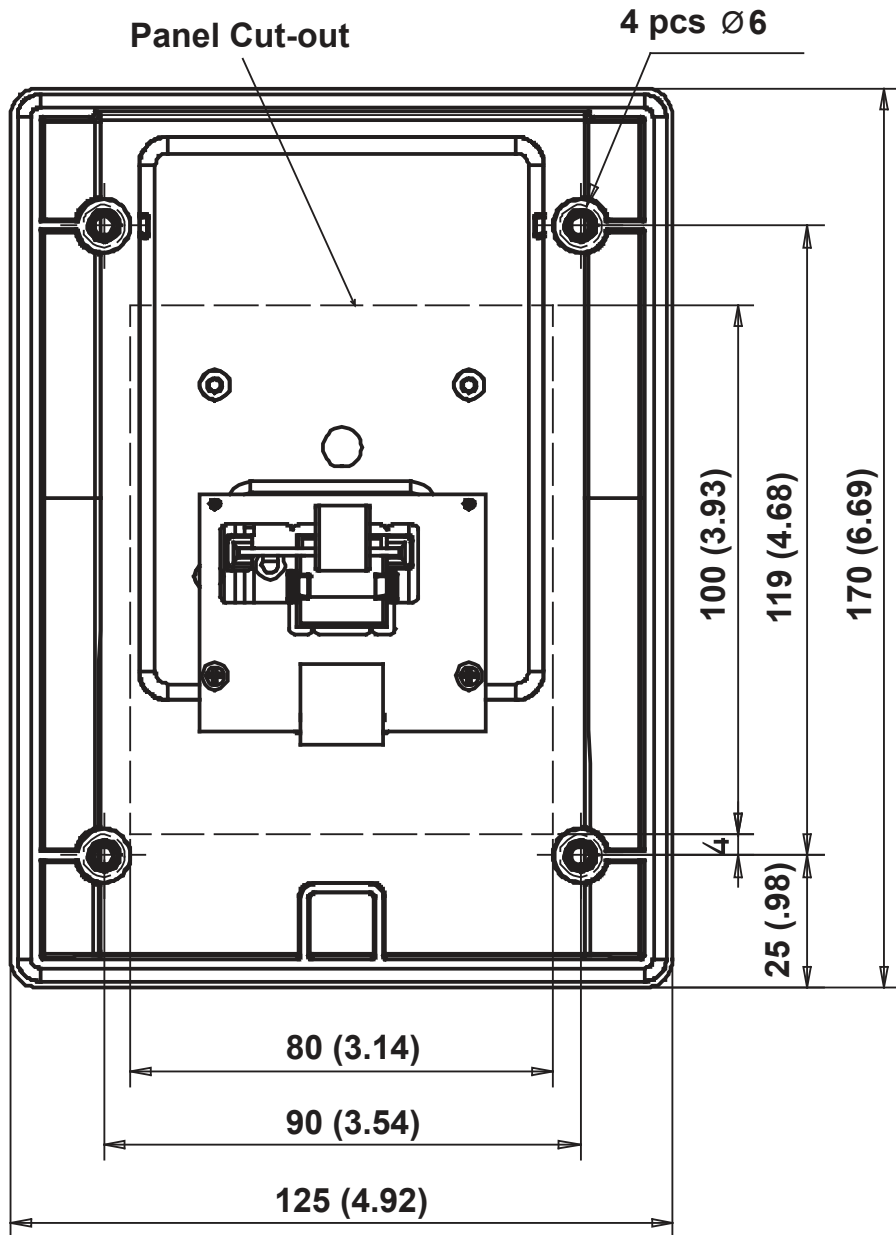

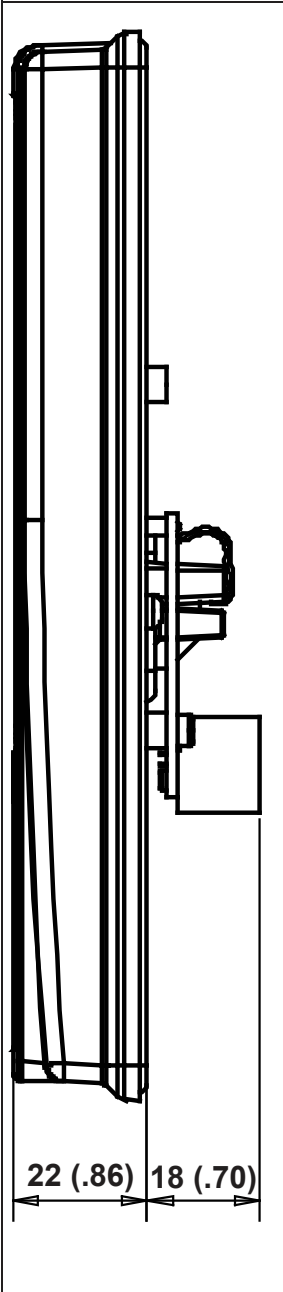

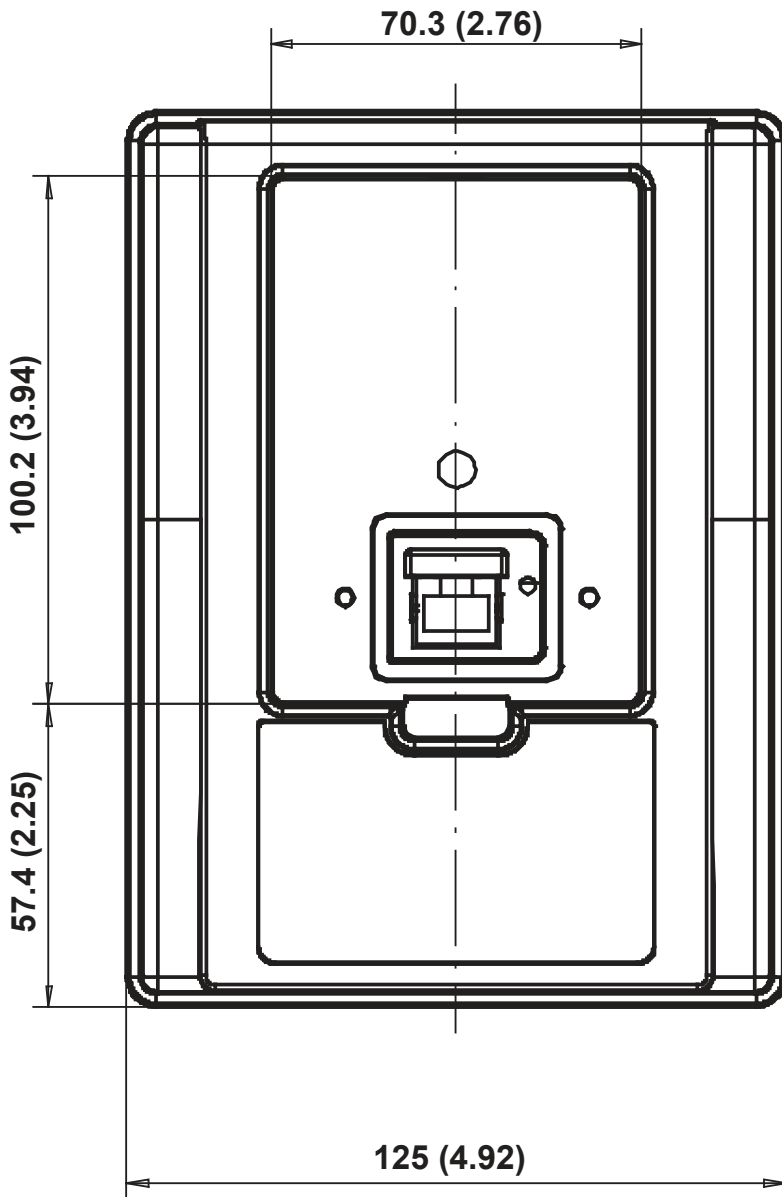

Information in this document is based on specifications believed correct at the time of publication. The right is reserved to make changes as design improvements are introduced. Product or company names mentioned herein may be the trademarks of their respective owners.
© 2013 Siemens Industry, Inc.

Siemens Industry, Inc.
Building Technologies Division
1000 Deerfield Parkway
Buffalo Grove, IL 60089-4513
USA
1-847-215-1000

Your feedback is important to us. If you have
comments about this document, please send them to
sbt_technical.editor.us.sbt@siemens.com.

